

GT-II

4-1 Civil

UNIT-4,56

Chapter 7

Pile Foundation

7.1 Introduction

Deep foundations are required when the soil at shallow depth is not capable of supporting structural loads. Deep foundation will be adopted if a firm stratum having desired bearing capacity cannot be reached by open excavation.

The purpose of pile foundations is to transmit a super structure load to deeper load bearing strata, to withstand lateral, vertical, uplift load and to minimize the settlement. A structure can be founded on piles if the soil immediately beneath its base does not have adequate bearing capacity to withstand the desired structural loads. If the results of site investigation show that the soil at shallow depth is unstable or if the estimated settlement is beyond acceptable limits, a pile foundation will be adopted.

7.2 Classification of Piles

Classification based on materials or composition:

1. **Timber piles:** Timber piles are made from tree trunks and are well seasoned, straight and free from all defects. Usually available length will be 4 to 6m. Timber piles are used where good bearing stratum is available at a relatively shallow depth.
2. **Concrete piles:** Concrete piles are either precast or cast in-situ. Precast piles are cast and cured at the casting yard and then transported to the site for installation. These piles are adequately reinforced to withstand handling stresses along with working stress. Precast piles are generally used for short lengths. Cast-in-situ piles are constructed by drilling hole in the ground and then filling that hole with freshly prepared concrete after placing the reinforcement.
3. **Steel Piles:** Steel piles are usually of rolled H-sections or thick pipe sections. These piles are used to withstand large impact stresses and where fewer disturbances from driving is desired. These piles are also used to support open excavations and to provide seepage barrier.

4. Composite piles: A pile made up of two different materials like concrete and timber or concrete and steel is called composite pile. Composite piles are mainly used where a part of the pile is permanently under water. The part of the pile which will be under water can be made of untreated timber and the other part can be of concrete.

Classification based on the function:

1. End bearing piles: Piles which transfer structural load to a hard and relatively incompressible stratum such as rock or dense sand are known as end bearing piles. These piles derive the required bearing capacity from end bearing at tip of the pile.

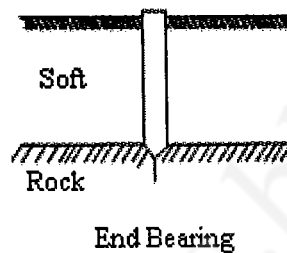

Fig.7.1a End bearing pile

2. Friction piles: These are piles which derive carrying capacity from skin friction or adhesion between the pile surface and surrounding soil.

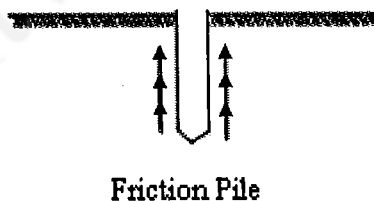

Fig.7.1b End bearing pile

3. Tension pile: These piles are also called as uplift piles. Generally it can be used to anchor down the structures which are subjected to uplift pressure due to hydrostatic force.

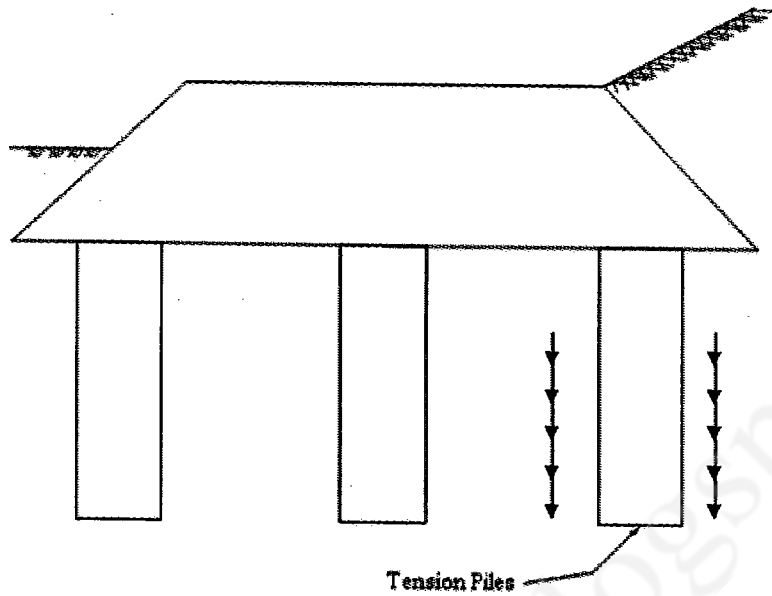

Fig.7.1c Tension pile

4. **Compaction piles:** These piles are used to compact loose granular soil to increase its bearing capacity. Compaction piles do not carry load and hence they can be of weaker material. Sand piles can be used as compaction piles.

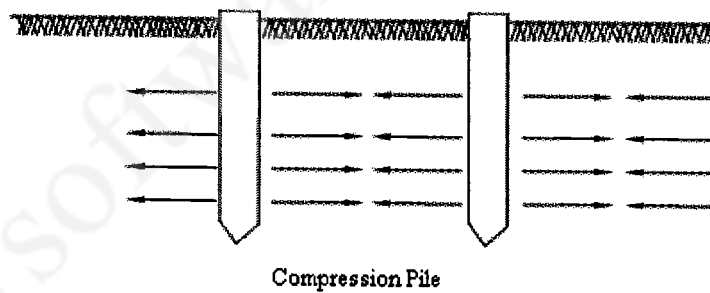

Fig.7.1d Compaction pile

5. **Anchor piles:** These piles are generally used to provide anchorage against horizontal pull from sheet piling.

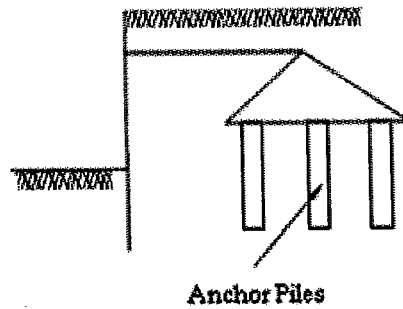

Fig.7.1e Compaction pile

6. Fender piles and dolphins: Fender piles and dolphins are used to protect water front structure from impact of any floating object or ships.

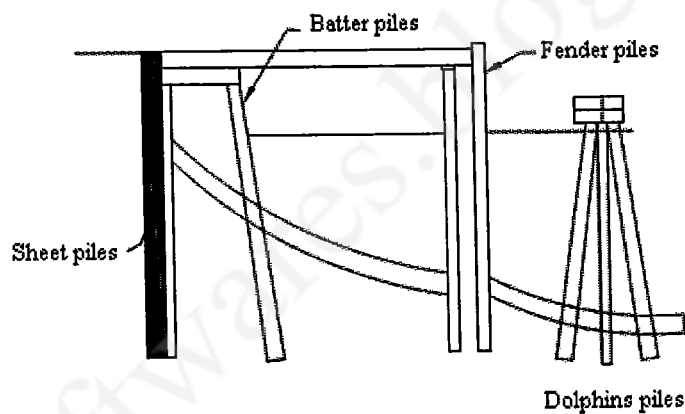

Fig.7.1f Compaction pile

Classification based on method of installation:

1. Bored piles: Bored piles are constructed in pre-bored holes either using a casing or by circulating stabilizing agent like bentonite slurry. The borehole is filled with concrete after placing or lowering reinforcement. The main advantage in bored piles is no damage due to handling and driving which is common in driven piles. The different types of bored piles are: small diameter piles up to 600mm diameter: Large diameter pile greater than 600mm; Under-reamed piles generally 300 to 450mm diameter.
2. Driven piles: Driven piles may be of concrete, steel or timber. These piles are driven into the soil strata by the impact of a hammer. Generally boring is not used in these cases.

When pile is driven into granular soils it densifies the soil and increases stiffness (strength) of soil.

3. Driven and Cast-in-Place Piles: These piles are formed by driving a tube with a closed end into the soil strata, and then filling the tube with freshly prepared concrete. The tube may or may not be withdrawn afterwards.

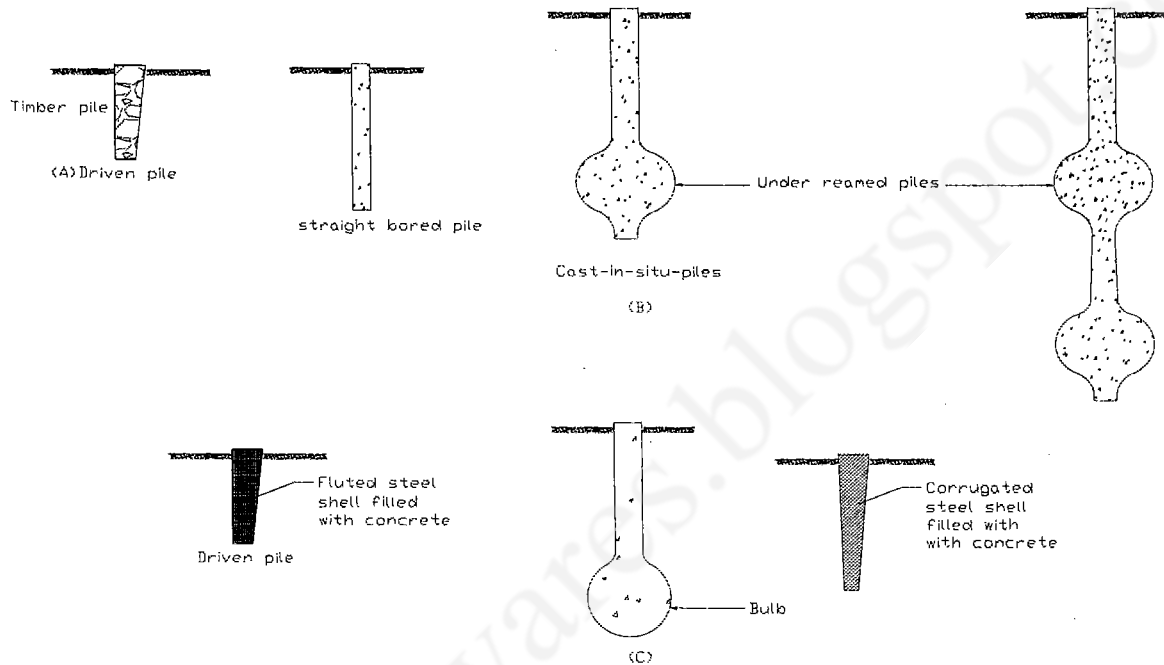

Fig. 7.2: Driven and Cast-in-situ piles

7.3 Load Transfer Mechanism

To understand the mechanism of distribution of applied load into skin resistance along length of pile and base resistance at top of pile, we consider the pile shown in Fig. 7.3 (a). If the pile is instrumented and the load on pile increased gradually, we can determine the load distribution along the pile at different stages of loading and plot the same as shown in Fig 7.3 (b).

When a load Q_1 is applied on the pile head, the axial load at pile top level is also Q_1 but at some level A_1 at distance L_1 below pile top the axial load is zero. The entire load Q_1 is thus distributed as skin resistance along pile length L_1 . The lower section A_1B of pile is not affected by the load Q_1 . We increase the load at pile top to Q_2 , such that the axial load at the top of pile is just zero. The total load applied Q_2 is distributed as skin

resistance along whole length L of pile. Any applied load greater than Q_2 will be distributed as skin resistance and point resistance. Both the components increase as the applied load is increased. But at some load level Q_m , the skin resistance reaches an ultimate value Q_f . further increase in applied load above Q_m will only result in increase in point load Q_p until the soil at base of pile fails by punching shear.

For any applied load the relative proportions of skin resistance and base resistance, mobilized depends on the shear strength and elasticity of soil. In general it is found that the vertical movement of pile which is required to mobilize full base resistance is much greater than that required to mobilize full skin resistance. For instance, in the case of bored cast insitu piles full skin resistance is mobilized at settlement of 0.5 to 1 percent of pile diameter, full base resistance is mobilized at settlement of 10 to 20 percent of pile diameter.

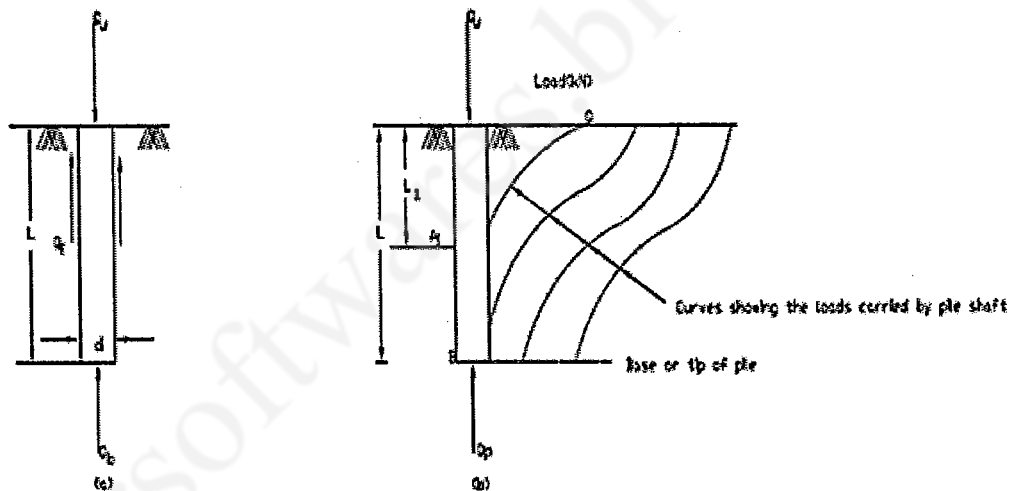

Fig.7.3: Load transfer mechanism

7.4 Load Carrying Capacity of Piles

The load carrying capacity of a single pile can be estimated using

1. Static formulae
2. Dynamic formulae
3. Correlations with penetration test data
4. Load tests

7.4.1 Static Formulae

The static formulae for ultimate load carrying capacity of pile based on soil properties and pile geometry are as given in Eq 7.1 and Eq 7.2 for piles in granular soils and cohesive soils respectively.

Piles in granular soils: The ultimate load Q_u is given by

$Q_u =$ End bearing resistance Q_p + Skin resistance Q_s

$$Q_u = A_p(0.5\gamma DN_\gamma) + A_p(\sigma' N_q) + \sum_{i=1}^n k A_{si}(\sigma'_i \tan \delta) \quad (\text{Eq.7.1})$$

where

A_p = Cross section area of pile.

D = Stem diameter of pile.

N_γ = Bearing capacity factor taken for general shear.

N_q = Bearing capacity factor.

σ' = Effective overburden pressure (Critical depth taken as 15D for $\phi \leq 30^\circ$ and 20D for $\phi \geq 40^\circ$)

k = Co-efficient of earth pressure.

σ'_i = Effective over burden pressure at middle of corresponding layer.

δ = Angle of wall friction usually taken as $\frac{3}{4} \phi$ of soil.

A_{si} = Surface area of pile.

Piles in cohesive soils

The ultimate bearing Q_u of piles in cohesive soils is given by the following formula

$Q_u =$ End bearing resistance Q_p + Skin resistance Q_s

$$Q_u = A_p N_c C_p + \sum_{i=1}^n \alpha A_{si} C_{si}$$

(Eq.7.2)

where

N_c = Bearing capacity factor in clays which is taken as 9 (See Skempton's curve)

c_p = Average cohesion at pile toe.

α_i = Adhesion factor.

c_i = Average cohesion of the i^{th} layer on the side of the pile.

A_{si} = Surface area of pile stem in the i^{th} layer.

$\alpha_i c_i$ = Adhesion between shaft of pile and clay.

Piles in C-Ø soils

Where the soil has large values of both c and ϕ (as for a true $c-\phi$), we should use the conservative Terzaghi's bearing capacity factors to determine the load carrying capacity

$$Q_u = A_p CN_c + \sigma_{vb} N_q + 0.5\gamma DN_\gamma + \sum_{i=1}^n A_s \alpha_c + k(\sigma_v \tan\phi)$$

(Eq.7.3)

where

N_c, N_q, N_γ = Terzaghi's bearing capacity factors

σ_{vb}, σ_v = Effective overburden pressure at base and pile shaft, irrespective of the critical depth.

7.4.2 Dynamic Formulae

For Piles driven in soils there are a set of formulae based on the so-called Engineering News (1888) formula.

$$Q_u = \frac{WHn}{s+c} \quad \text{(Eq.7.4)}$$

where, Q_u = Ultimate load capacity of the driven pile.

W = Hammer weight (tons)

H = Height of fall of hammer (cm)

S = Final set (cm/blow)

C = a constant depending on type of hammer (2.54 for drop hammer, 0.254 for steam hammer)

η_h = efficiency of hammer (0.65 for steam hammer, 1.0 for drop hammer)

For double-acting steam hammer

The hammer weight W is replaced by $W+ap$,

where 'a' is the area of the piston (cm^2) and p is the steam pressure (kg/cm^2).

$$Q_a = \frac{Q_u}{F}$$

where, Q_a = allowable load

F is taken as 6.

7.4.2.2 Hiley's Modification of Wellington's formula

$$Q_u = \frac{WH\eta_h\eta_b}{s + \left(\frac{C}{2}\right)} \quad (\text{Eq.7.5})$$

where, the terms W, H, η_h and S are the same as before.

η_b is the efficiency of the hammer blow.

$$\eta_b = \frac{W + Pe^2}{W + Pe} \quad \text{if } W > ep$$

$$\eta_b = \frac{W + Pe^2}{W + Pe} \quad \text{if } W < ep$$

Here P is the pile weight and e is the co-efficient of restitution, whose value is 0.4 for concrete and 0.5 for steel.

The quantity C in Hiley's formula is total elastic compression given by

$$C = C_1 + C_2 + C_3$$

where, C_1 , C_2 , C_3 are the compression of pile cap, pile shaft and soil respectively.

Dynamic formulae are generally found to be less reliable than static formulae.

7.4.3 Load Carrying Capacity from Penetration Test Data

Static cone penetration test data and standard penetration test data are often used to determine the pile load capacity.

The point resistance of driven piles in sand including H piles, can also be determined using N values as per the below equation.

$$q_{pu} = 40N \left(\frac{L}{D} \right) \text{ kN/m}^2$$

where N is the standard penetration resistance as observed in the field for bearing stratum without the overburden corrections

Data from a static cone penetration test can be used to estimate the unit skin friction.

$$f = aq_c$$

where, q_c = static cone resistance in kg/cm^2 and a is coefficient whose value depends on the soil type (0.04 to 0.08 for clays, 0.01 to 0.04 for silty sands, 0.01 to 0.02 for sands).

The maximum unit skin friction for steel H-piles is taken as 0.5 kg/cm^2 and for driven concrete piles it is 1.0 kg/cm^2

For driven steel or concrete piles the point resistance may be obtained from the SPT N value

$$q = 4N \left(\frac{l}{d} \right)$$

For bored concrete piles

$$q = 1.4N \left(\frac{l}{d} \right)$$

7.4.4 Load Tests on Piles

Before finalizing the design, load tests are carried out on piles installed for the purpose on the site. These are called initial load tests. They are useful in determining the general suitability of the proposed pile foundation, comparing the load capacity obtained from formulae, and for a general check on the piling equipment to be used as well as on soil properties.

Procedure for pile load test

The pile head is chipped off to natural horizontal plane till sound concrete is met. The projecting reinforcement is cut off suitably and the top is finished smooth & level with plaster of Paris. Loading platform of 6.2m x 6.2m is constructed by using 2nos. of ISMB 500 as main girders and 21nos of ISMB 300 as secondary girders.



Fig. 7.4 (a): Pile load Test Setup

The CG of platform is made to coincide with centre of pile. Platform thus constructed is loaded with sand bags for required weight. A 20mm thick mild steel plate is placed on the top of

pile head, Hydraulic jack of 250T Capacity is placed centrally on top of the plate. The gap between the top of jack and bottom of main girders is filled with steel packing materials. The Hydraulic pump is connected to jack by flexible pressure hose. Calibrated pressure gauge is connected to hydraulic pump. Datum bars of heavy sections were placed very near to pile head and are supported on ends at a distance of 2m on either side from face of the pile. Two numbers of settlement gauges are placed on pile head at diametrical opposite locations with the help of magnetic bases fixed on datum bars.



Fig. 7.4(b): Pile load Test Setup

The pump is operated till the ram of jack touches the bottom of main girders. At this stage the pressure gauge reading is zero and dial gauge reading are adjusted for zero loading. The loads are then applied in increments of 20% of safe load. For each increment of load the dial gauge reading are taken at intervals of 15 minutes, till the rate of settlement is less than 0.1 mm in the first half hour or 0.2 mm in one hour or for a maximum period of 2hrs. Then the next increment of load is applied and the procedure repeated till the test load is reached. This load is maintained for 24 hours and hourly settlement readings are noted. At the end of 24 hours, unloading is done gradually till the entire load is released.

Allowable load from single pile load test data

There are different methods for determining the allowable loads on a single pile which can be determined by making use of load test data. If the ultimate load can be determined from

load-settlement curves, allowable loads are found by dividing the ultimate load carried by a pile by suitable factor of safety which varies from 2 to 3. Normally a factor safety is 2.5 is recommended.



Fig. 7.5: Determination of Ultimate load from load-settlement curve

1. The ultimate load, Q_u can be determined as the abscissa of the point where the curved part of the load-settlement curve changes to falling straight line, Fig. 7.5(a)
2. Q_u is the abscissa of the point of intersection of the initial and final tangents of the load-settlement curve, Fig.7.5(b)
3. The allowable load Q_a is 50 percent of the ultimate load at which the total settlement amounts to one-tenth of the diameter of the pile.
4. The allowable load Q_a is sometimes taken as equal to two-thirds of the load which causes a total settlement of 12mm.
5. The allowable load Q_a is sometimes taken as equal to two-thirds of the load which causes a net settlement of 6mm.

7.5 Pile settlements

Pile settlement can be estimated as follows.

1. Compute the average pile axial force in each segment of length L , average cross-section & A_{av} and shaft modulus of elasticity E_p from the pile butt to point. That is.

$$\Delta H_{s,s} = \frac{P_{av} \times \Delta L}{A_{av} \times E_p}$$

and sum the several values to obtain the axial total compression

$$\Delta H_a = \sum \Delta H_{s,s}$$

2. Compute the point settlement using the equation below.

$$\Delta H_{pt} = \Delta q D \left(\frac{1-\mu^2}{E_s} \right) m I_s I_F F_1$$

Where,

$$m I_s = 1$$

I_f = Fox embedment factor, with values as follows:

$$I_f = 0.55 \text{ if } L/D \leq 5$$

$$= 0.5 L/D > 5$$

D = diameter of the pile

μ = Poisson's ratio

q = bearing pressure at point = input load / A_p

E_s = Young's modulus

SPT: $E_s = 500 (N+15)$

CPT: $3-6 q_c$

F_1 is the reduction factor as follows

0.25 if the axial skin resistance reduces the point load $P_p \leq 0$

0.5 if the point load $P_p > 0$

0.75 if the point bearing

7.6 Negative Skin Friction

When a weak, compressible soil layer is sandwiched between hard layers, a pile passing through such a stratum may be subjected to an additional load due to compression of the weak layer. This compression may be caused by consolidation, fill placing, remolding during driving, or lowering of the water table. The portion of the pile within this layer is subjected to draw

down force in addition to the structural loads. This force should be taken into account when designing the pile foundation.

An approximate estimate of the force can be made by empirical formulae such as following

F_d = force due to negative skin friction

$F_d = (\text{perimeter} * \text{soil depth}) * C_u$ [for clays]

$F_d = 0.5(\text{perimeter} * (\text{soil depth})^2 * \gamma K \tan \delta)$ [for sands]

C_u = undrained shear strength

γ = unit weight of soil

K = coefficient of earth pressure, δ = angle of internal friction.

7.7 Under-Reamed Piles

These are bored, cast in-situ, concrete piles with one or more bulbs formed by enlarging the pile stem. They are suitable for loose and filled up sites, or where soils are weak or expansive like black cotton soil.

The bulbs are located at depths where good bearing strata are available but they should not be placed too near the ground level. Bulb size is usually 2 to 3 times the pile stem diameter. The bulb provides a large bearing area, increasing the pile load capacity. They are also effective in resisting the downward drag due to the negative skin friction that arises in loose or expansive soils. Bulb spacing should not exceed 1.5 times the bulb diameter.

7.7.1 Procedure for Construction of Under-Reamed Piles

The hole is drilled to the full required depth using augers. The under reaming tool consists of a link mechanism attached to a vertical rod with a handle at the top and connected to a bucket at the bottom. The link mechanism incorporates cutting blades. The under reaming tool is inserted into the hole. When the central rod is pressed by the handle the mechanism actuates the cutting blades to open out. The mechanism is now made to rotate keeping the handle under pressure. The blades now scrap the soil from the sides of the hole which falls into the bucket below. The rotation under pressure is continued until the full amount of soil forming the bulb is removed which is identified by the free rotation of the mechanism. The volume of the bucket is such that it gets filled when the bulb is fully formed. The handle is now tightened which makes

the link mechanism to collapse back into the position. The under reamed tool is now withdrawn, the reinforcement cage inserted and the hole concreted.

7.8 Group Action

Piles are generally used in groups with a common pile cap. A group may consist of two or three, or as many as ten to twelve piles depending on the design requirement. The load carrying capacity of a group of piles is given by

$$(Q_u)_g = Nq_u n \quad (\text{Eq.7.6})$$

where,

$(Q_u)_g$ = Load carrying capacity of pile group

N = number of piles

q_u = allowable load per pile

n = group efficiency

Its value for bearing or friction piles at sites where the soil strength increases with depth is found to be 1.

For friction piles in soft clays the value on n is less than 1. The actual value of n depends on soil type, method of pile installation, and pile spacing.

When piles are driven in loose, sandy soils, the soil is densified during driving, and $n > 1$ in such cases.

It has been observed that if the spacing between piles is more than 2.5 times the pile diameter, the group efficiency is not reduced.

The large pile to pile spacing will increase the overall cost of construction. The reduction in load capacity due to the group effect can be estimated empirically.

The use of Feld's rule is probably the simplest. It states that the load capacity of each pile in a group is reduced by 1/16 on account of the nearest pile in each diagonal or straight row.

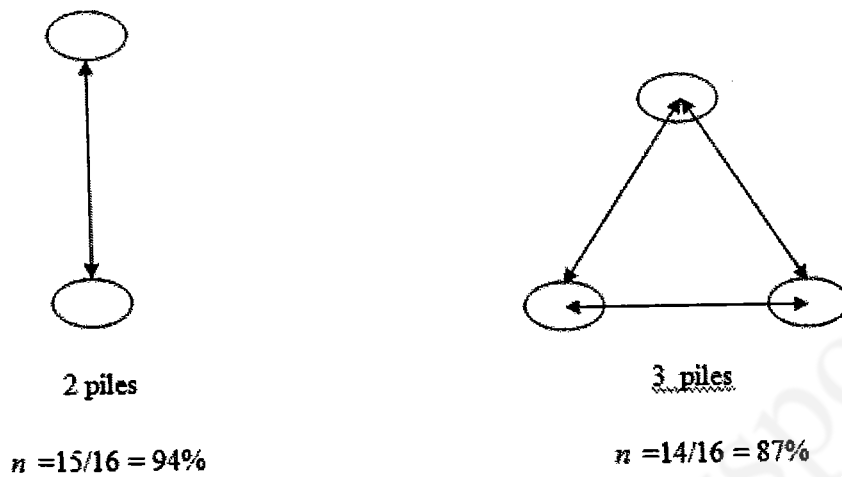

Fig. 7.6: Group action of piles- Feld's rule

A group of piles may fail as a block, i.e., by sinking into the soil and rupturing it at the periphery of the group Fig. 7.7.

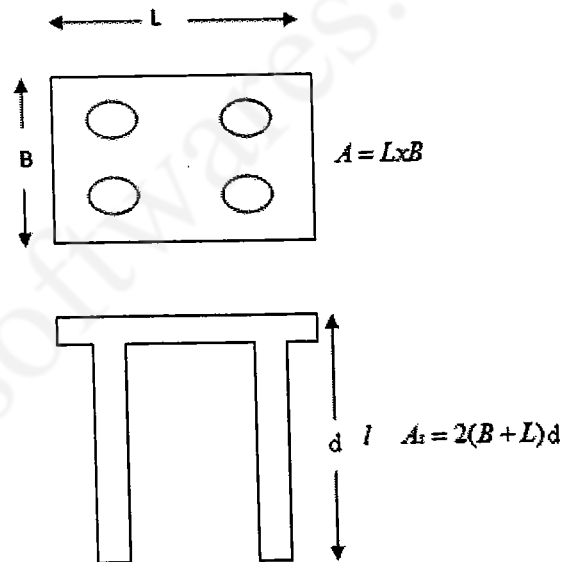

Fig.7.7: Failure of a pile group as a block

7.8.1 Ultimate Load Carrying Capacity for the Pile Group

The ultimate load carrying capacity for the pile group taken as a block is given by

$$(Q_u)_g = C_u N_c A_b + C_u A_p \text{ (Eq 7.7)}$$

where A_p and A_b are the area of the base and the surface area of block. i.e. $A_b = LB$

where, L and B are the dimensions of the pile cap.

A_p is the perimeter of the block times the embedded length of the pile.

The Ultimate load capacity for the group is also evaluated as

(Eq.7.8)

Here each pile is assumed to individually carry the same load, whether in group or as a single pile. The load carrying capacity of a pile group is taken to be the smaller of the two values obtained from Eqs.7.7 and 7.8.

7.8.2 Efficiency of a Pile Group

The efficiency of a pile group is defined as

$$\eta_g = \frac{\text{Ultimate bearing capacity of the group}}{n \times \text{ultimate bearing capacity of single pile in the group}}$$

where n = number of piles in the group

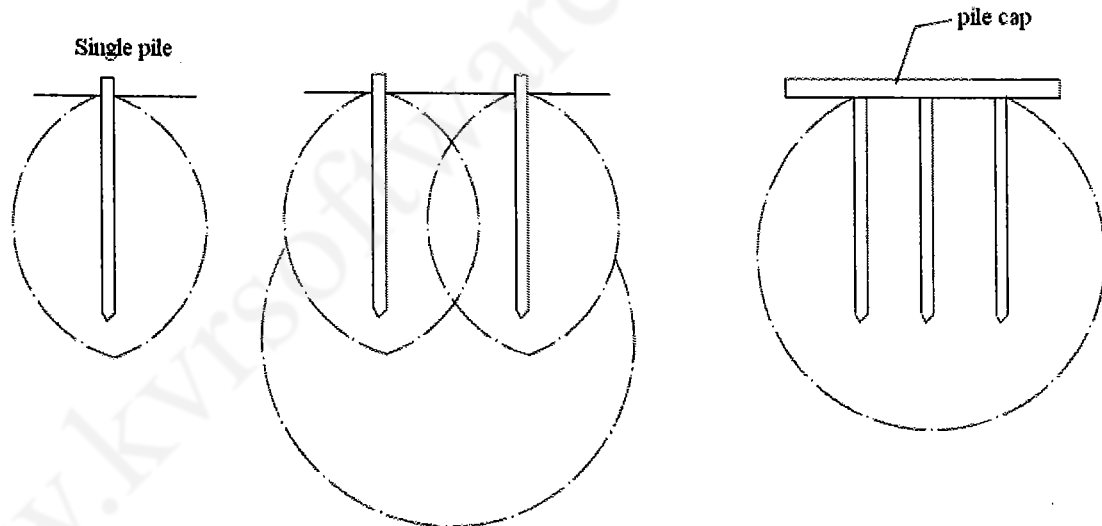

Fig. 7.8: Group action of Piles

7.8.3 Settlement of Pile Groups

Due to group action, both immediate and consolidation settlement values of a pile group are greater than those for a single pile.

For bearing piles the total foundation load is assumed to act at the base of the piles on an imaginary foundation of the same size as the plan of the pile group as show in Fig 7.9 (b)

For friction piles it is virtually impossible to determine the level at which the structural load is effectively transferred to the soil. The level used in design is at a depth of two-thirds the penetration depth.

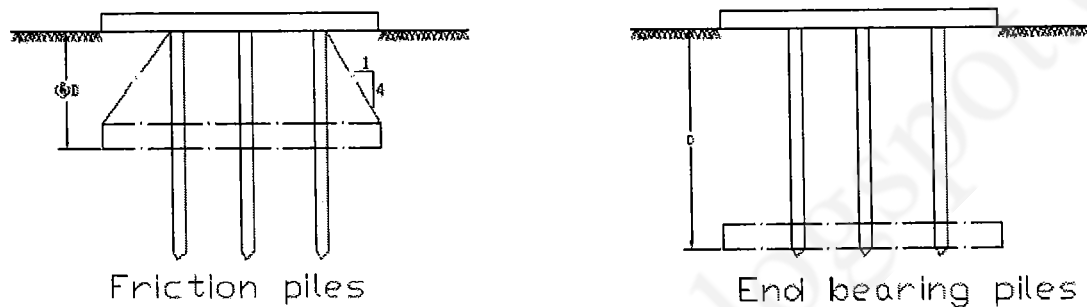

Fig.7.9: Equivalent foundations for pile

7.8.4 Multi-Layered Deposits

Driven piles through a multi-layer deposit can be calculated by their load capacities from both skin and point resistance and these capacities may need to be confirmed by load tests. Whenever possible, piles should be driven to a layer of sufficient strength and thickness that they derive their load capacity entirely from the layer.

$$q' = \frac{q}{(B+1.15H')(L+1.15H')} \quad (\text{Eq.7.9})$$

for a side slope of 30 degrees,

$$\text{Or } q' = \frac{q}{(B+H')(L+H')} \quad (\text{Eq.7.10})$$

for a side slope of 2:1.

If the strength of the underlying clay layer is c , the margin of safety against a punching failure will be sufficient if:

$$q' \leq 3c$$

7.9 Eccentric and Inclined Loads on Pile Groups

When horizontal force acting on a pile group is accompanied by a vertical load, due to the weight of the pile cap or some supported structure. In a pile cap acted upon by an eccentric inclined load which will distribute itself into the piles.

If there is no horizontal load and if the vertical load is concentric with the centroid of the pile group, the load in each pile is simply taken to be equal to the total load divided by the total number of piles.

$$Q_p = \frac{Q_v}{n}$$

Q_p = total vertical load

Q_v = vertical load per pile

n = number of piles

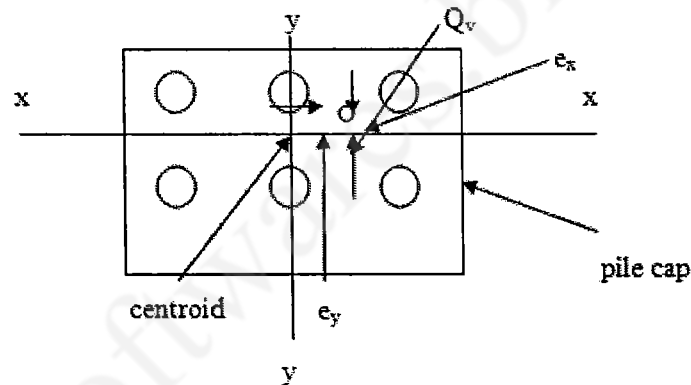

Fig. 7.10: Pile group with eccentric vertical load

Consider a pile in the group at distance X and Y from the centroid of the group.

From the theory of bending of beams, tensile and compressive stresses at a distance Y , from the neutral axis given by

$$f_b = \pm \frac{M_y}{I}$$

where,

M = applied moment

I = moment of inertia of beam section

Total vertical load induced in the pile can be expressed by

$$Q_p = \frac{Q_v}{n} \pm \frac{A_b Y M_x}{I_x} \pm \frac{A_b X M_y}{I_y}$$

$$I_x = I_o + A_b \sum Y^2 = A_b \sum Y^2$$

Since, I_o = moment of inertia of the pile section in negligible.

$$I_y = A_b \sum X^2$$

$$M_x = Q_v e_y \text{ And } M_y = Q_v e_x$$

Hence

$$Q_p = \frac{Q_v}{n} \pm \frac{A_b Y M_x}{I_x} \pm \frac{A_b X M_y}{I_y}$$

$$Q_p = Q_v \left(\frac{1}{n} + \frac{X e_x}{\sum X^2} + \frac{Y e_y}{\sum Y^2} \right) \text{ (Eq. 7.11)}$$

7.10 Laterally Loaded piles

Structures supported on pile foundation are often subjected to lateral loads and moments in addition to vertical loads. The sources of lateral loads are traffic, seismic events, wind, waves, and earth pressure. Moments may arise due to the eccentricity of the vertical force, fixity of the superstructure to the foundation and the location of the resultant lateral force on the pile with reference to the ground surface.

There are two types of piles encountered in practice.

1. Long pile ($L/d > 30$)
2. Short pile ($L/d < 20$)

In the case of long pile: When a pile is greater than a particular length, the length loses its significance. The behavior of the pile will not be affected if the length is greater than this particular length.

Three types of boundary conditions are normally applicable.

1. Fixed-headed pile.
2. Free-head pile.
3. Partially-restrained-head pile.

In the case of free-head piles, the lateral load may act at or above ground level and the pile head is free to rotate without any restraint.

In the case of fixed head piles, the pile is free to move only laterally but rotation is prevented completely, where as a pile with a partially restrained head moves and rotates under restraint.

The partially restrained head is normally encountered in offshore drilling platforms and other similar structures.

The analysis of laterally loaded single piles is based on the following assumptions.

1. The laterally loaded pile behaves as an elastic member and the supporting soil behaves as an ideal elastic material.
2. The theory of sub-grade reaction
3. There is no axial load.

The different methods for solving the problem of laterally loaded piles are;

1. Closed-Form solution
2. Difference equation method
3. Non-dimensional method
4. A direct method
5. Pressure-meter method
6. Broms method
7. Polulos Method

When a horizontal load is applied to the head of a vertical pile which is free to move in any lateral direction, the load is initially carried by the soil close to the ground surface. However the soil compress elastically and there is some transfer of load to the soil at a greater depth. When the horizontal load is increased the soil yields plastically and the load transfer extends to greater depths.

In the case of short pile: the flexural stiffness EI of the material of the pile loses its significance. The pile behaves as a rigid member and rotates as a unit.

Failure occurs by rotation when the passive resistance at the head and toe are exceeded.

Non-dimensional solutions for laterally loaded piles in a soil deposit in which the subgrade modulus increases linearly with depth, have been developed by Reese and Matlock (1956). The

solutions have been developed for long piles when $L/T > 5$, where L is the length of the pile and T is the relative stiffness factor given by below equation.

$$T = (EI/n_h)^{1/5}$$

Where E and I are the modulus of elasticity and the moment of inertia of the soil respectively; n_h is the unit modulus of the subgrade reaction.

For a vertical pile length L , subjected to horizontal load Q_g at the ground level and a moment M_g at the ground level, the solution for deflection y may be expressed as a function of various quantities.

$$y = f(x, T, L, K, EI, Q_g, M_g)$$

Using the principle of superposition,

$$y = y_A + y_B$$

y = total deflection of the pile at any depth

y_A = deflection due to the horizontal load Q_g

y_B = deflection due to moment M_g at ground level

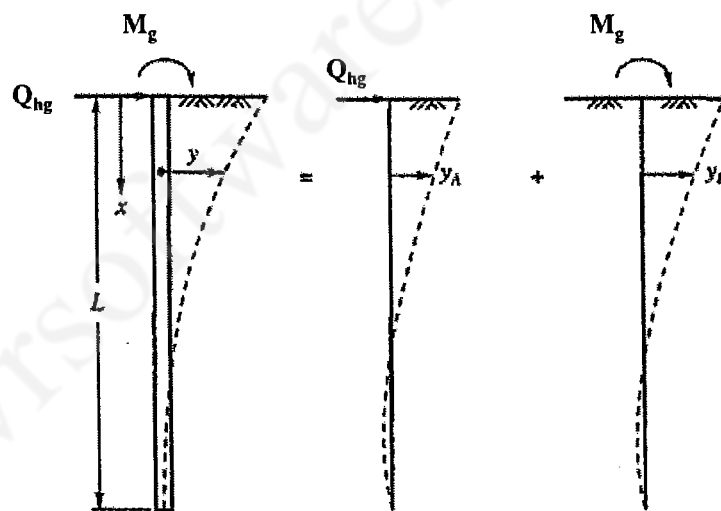

Fig. 7.11. Principle of superposition in laterally loaded piles

$$y = \left(\frac{Q_g T^3}{EI} \right) A_y + \left(\frac{M_g T^2}{EI} \right) B_y$$

Where

$$A_y = \left(\frac{y_A EI}{Q_g T^3} \right) \text{ and } B_y = \left(\frac{y_B EI}{M_g T^2} \right)$$

7.11 Piles on a Rocky Bed

Piles are required to be driven through weak layers of soil until the tips meet a hard stratum for bearing. If the bearing strata found to be rock, the piles are to be driven to refusal to obtain the maximum load carrying capacity from the piles. If the rock is found to be strong at its surface, the pile will refuse further driving at a negligible penetration. In these cases the load carrying capacity of the piles is governed by the strength of the pile shaft. If the soil mass through which the piles are driven happens to be stiff clays or sands, the piles can be regarded as being supported on all sides from buckling as a strut. In these cases, the capacity of a pile is calculated from the safe load on the material of the pile at the point of minimum cross-section.

If piles are driven to weak rocks, working loads as calculated by the available stress on the material of the pile shaft may not be possible. In these cases frictional resistance developed over the penetration into the rock and the end bearing resistance are required to be calculated.

Tomlinson (1986) suggested an equation for calculating the end bearing of piles resting on rock strata.

$$q_u = 2N_\phi q_{ur}$$

where $N_\phi = \tan^2(45 + \phi/2)$, q_{ur} = Unconfined compressive strength of the rock.

Module 9

(Lecture 40)

DRILLED-SHAFT AND CAISSON FOUNDATIONS

Topics

1.1 CAISSONS

1.2 TYPES OF CAISSONS

1.3 THICKNESS OF CONCRETE SEAL IN OPEN CAISSONS

1.4 EXAMPLES & SOLUTIONS

- **Check for Perimeter Shear**
- **Check Against Buoyancy**

CAISSONS

TYPES OF CAISSONS

Caissons are divided into three major types: (1) open caissons, (2) box caissons (or closed caissons), and (3) pneumatic caissons.

Open caissons (**figure 9.30**) are concrete shafts that remain open at the top and bottom during construction. The bottom of the caisson has a cutting edge. The caisson is sunk into place, and soil from the inside of the shaft is removed by grab buckets until the bearing stratum is reached. The shafts may be circular, square, rectangular, or oval. Once the bearing stratum is reached, concrete is poured into the shaft (under water) to form a seal at its bottom. When the concrete seal hardens, the water inside the caisson shaft is pumped out. Concrete is then poured into the shaft to fill it. Open caissons can be extended to great depths, and the cost of construction is relatively low. However, one of their major disadvantages is the lack of quality control over the concrete poured into the shaft for the seal. Also, the bottom of the caisson cannot be thoroughly cleaned out. An alternative method of open-caisson construction is to drive some sheet piles to form an enclosed area, which is filled with sand and is generally referred to as a *sand island*. The caisson is then sunk through the sand to the desired bearing stratum. This procedure is somewhat analogous to sinking a caisson when the ground surface is above the water table.

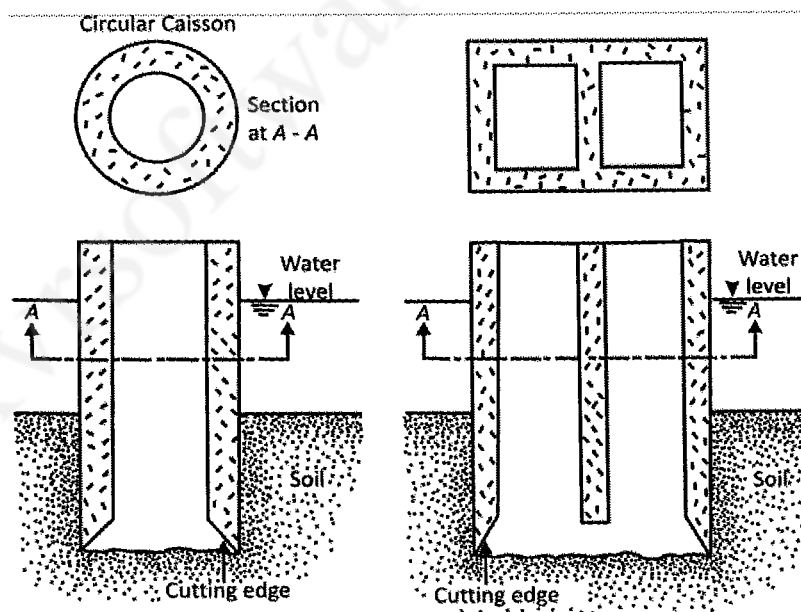

Figure 9.30 Open caisson

Box caissons (figure 9. 31) are caissons with closed bottoms. They are constructed on land and then transported to the construction site. They are gradually sunk at the site by filling the inside with sand, ballast, water, or concrete. The cost for this type of construction is low. The bearing surface must be level, and if it is not, it must be leveled by excavation.

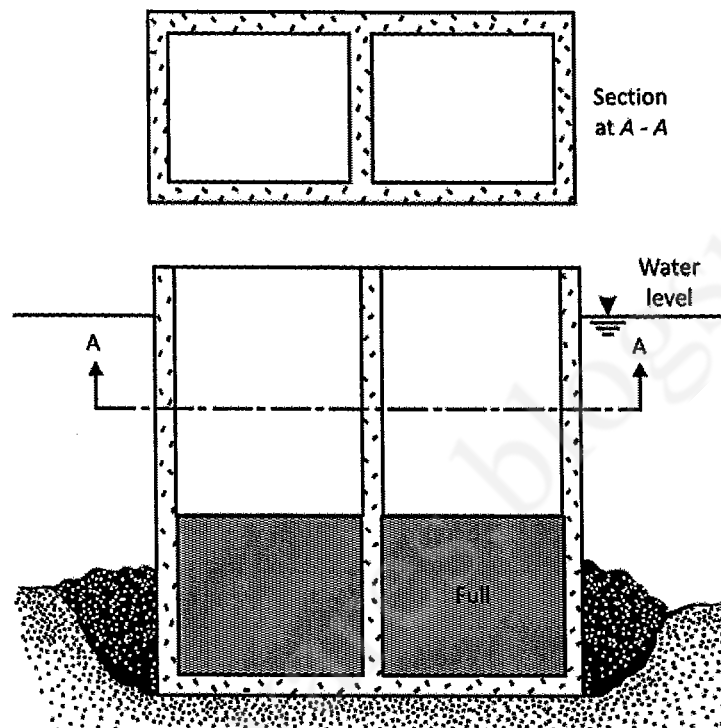

Figure 9.31 Box caisson

Pneumatic caissons (figure 9. 32) are generally used for depths of about 50-130 ft (15-40 m). This type of caisson is required when an excavation cannot be kept open because the soil flows into the excavated area faster than it can be removed. A pneumatic caisson has a work chamber at the bottom that is at least 10 ft (≈ 3 m) high. In this chamber, the workers excavate the soil and place the concrete. The air pressure in the chamber is kept high enough to prevent water and soil from entering. Workers usually do not counter severe discomfort when the chamber pressure is raised to about 15 lb/in^2 ($\approx 100 \text{ kN/m}^2$) above atmospheric pressure. Beyond this pressure, decompression periods are required when the workers leave the chamber. When chamber pressures of about 44 lb/in^2 ($\approx 300 \text{ kN/m}^2$) above atmospheric pressure are required, workers should not be kept inside the chamber for more than $1\frac{1}{2}$ hours at a time. Workers enter and leave the chamber through a steel shaft by means of a ladder. This shaft is also used for the removal of excavated soil and the placement of concrete. For large caisson construction, more than one shaft may be necessary, an airlock is provided for each one. Pneumatic caissons gradually sink as excavation proceeds. When the bearing stratum is reached, the work

chamber is filled with concrete. Calculation of the load-bearing capacity of caissons is similar to that for drilled shafts. Therefore, it will not be further discussed in this section.

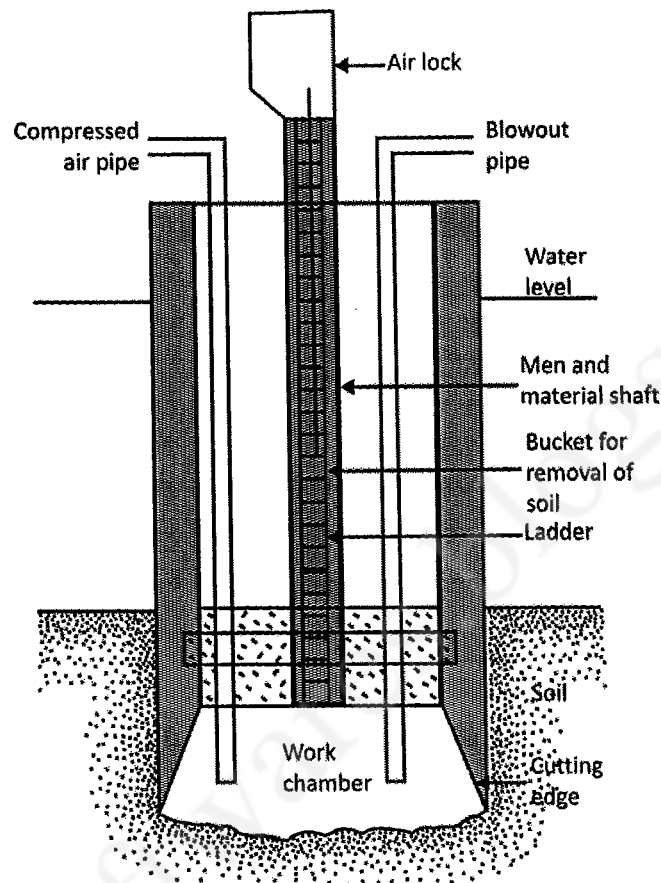

Figure 9.32 Pneumatic caisson

THICKNESS OF CONCRETE SEAL IN OPEN CAISSONS

In section 3, we mentioned that, before dewatering the caisson, a concrete seal is placed at the bottom of the shaft (figure 9.33) and allowed to cure for some time. The concrete seal should be thick enough to withstand an upward hydrostatic force from it bottom after dewatering is complete and before concrete fills the shaft. Based on the theory of elasticity the thickness, t , according to Teng (1962) is

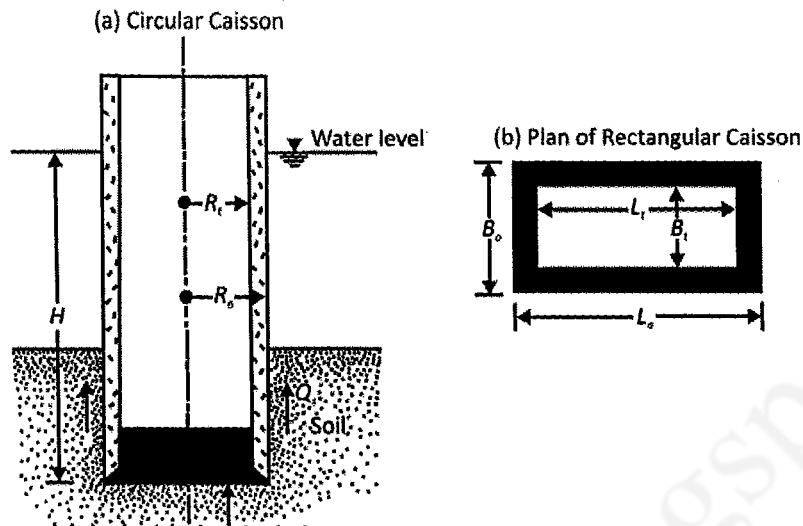

Figure 9.33 Calculation of the thickness of seal for an open caisson

$$t = 1.18R_i \sqrt{\frac{q}{f_c}} \quad (\text{circular caisson}) \quad [9.48]$$

And

$$t = 0.866B_i \sqrt{\frac{q}{f_c \left[1 + 1.61 \left(\frac{L_i}{B_i} \right) \right]}} \quad (\text{rectangular caisson}) \quad [9.49]$$

Where

R_i = inside radius of a circular caisson

q = unit bearing pressure at the base of the caisson

f_c = allowable concrete flexural stress ($\approx 0.1 - 0.2$ of f'_c where f'_c is than 28 – day compressive strength of concrete)

B_i, L_i = inside width and length, respectively, of rectangular caisson

According to figure 9. 33, the value of q in equations (48 and 49) can be approximated as

$$q \approx H\gamma_w - t\gamma_c \quad [9.50]$$

Where

γ_c = unit weight of concrete

The thickness of the seal calculated by equations (48 and 49) will be sufficient to protect it from cracking immediately after dewatering. However, two other conditions should also be checked for safety.

1. Check for Perimeter Shear an Contact Face of Seal and Shaft

According to figure 9. 33, the net upward hydrostatic force from the bottom of the seal is $A_i H \gamma_w - A_i t \gamma_c$ (where $A_i = \pi R_i^2$ for circular caissons and $A_i = L_i B_i$ for rectangular caissons). So the perimeter shear developed is

$$v \approx \frac{A_i H \gamma_w - A_i t \gamma_c}{p_i t} \quad [9.51]$$

Where

p_i = inside perimeter of the caisson

Note that

$$p_i = 2\pi R_i \quad (\text{for circular caissons}) \quad [9.52]$$

And that

$$p_i = 2(L_i + B_i) \quad (\text{for circular caissons}) \quad [9.53]$$

The perimeter shear given by equation (51) should be less than the permissible shear stress, v_u , or

$$v (\text{MN/m}^2) \leq v_u (\text{MN/m}^2) = 0.17\phi \sqrt{f'_c} (\text{MN/m}^2) \quad [9.54]$$

Where

$$\phi = 0.85$$

In English units,

$$v (\text{lb/in}^2) \leq v_u (\text{lb/in}^2) = 2\phi \sqrt{f'_c} (\text{lb/in}^2) \quad [9.55]$$

Where

$$\phi = 0.85$$

2. Check for Buoyancy

If the shaft is completely dewatered, the buoyant upward force, F_u , is

$$F_u = (\pi R_0^2) H \gamma_w \quad (\text{for circular caissons}) \quad [9.56]$$

And

$$F_u = (B_0 L_0) H \gamma_w \quad (\text{for rectangular caissons}) \quad [9.57]$$

The downward force, F_d , is caused by the weight of the caisson and the seal and by the skin friction at the caisson-soil interface, or

$$F_d = W_c + W_s + Q_s \quad [9.58]$$

Where

W_c = weight of caisson

W_s = weight of seal

Q_s = skin friction

If $F_d > F_u$, the caisson is safe from buoyancy. However, if $F_d < F_u$, dewatering the shaft completely will be unsafe. For that reason, the thickness of the seal should be increased by Δt [over the thickness calculated by using equation (48) or (49)] or

$$\Delta t = \frac{F_u - F_d}{A_i \gamma_c} \quad [9.59]$$

Example 10

An open caisson (circular) is shown in **figure 9.34**. Determine the thickness of the seal that will enable complete dewatering.

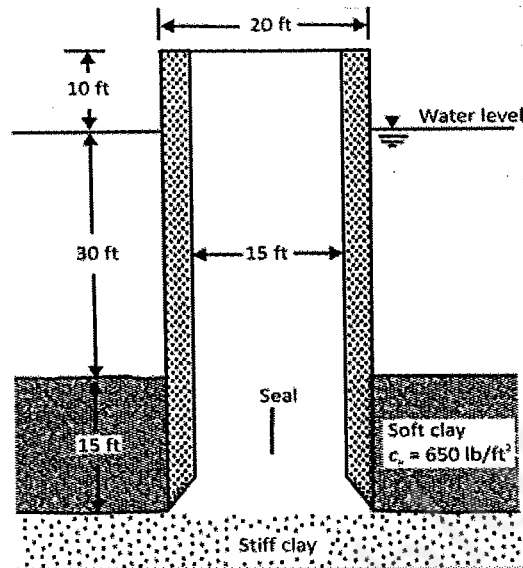

Figure 9.34

Solution

From equation (48),

$$t = 1.18R_i \sqrt{\frac{q}{f_c}}$$

For $R_i = 7.5$ ft,

$$q \approx (45)(62.4) - t\gamma_c$$

With $\gamma_c = 150$ lb/ft³, $q = 2808 - 150t$ and

$$f_c = 0.1f'_c = 0.1 \times 3 \times 10^3 \text{ lb/in}^2 = 0.3 \times 10^3 \text{ lb/in}^2$$

So

$$t = (1.18)(7.5) \sqrt{\frac{(2808 - 150t)}{300 \times 144}}$$

Or

$$t^2 + 0.07t - 5.09 = 0$$

NPTEL – ADVANCED FOUNDATION ENGINEERING-I

$$t = 2.2 \text{ ft}$$

Use $t \approx 2.5 \text{ ft}$

Check for Perimeter Shear

According to equation (51),

$$v = \frac{\pi R_i^2 H \gamma_w - \pi R_i^2 t \gamma_c}{2\pi R_i t} = \frac{(\pi)(7.5)^2[(45)(62.4) - (2.5)(150)]}{(2)(\pi)(7.5)(2.5)} \approx 3650 \text{ lb/ft}^2$$
$$= 25.35 \text{ lb/in}^2$$

The allowable shear stress is

$$v_u = 2\phi\sqrt{f_c} = (2)(0.85)\sqrt{3000} = 29.4 \text{ lb/in}^2$$

$$v = 25.35 \text{ lb/in}^2 < v_u = 29.4 \text{ lb/in}^2 - \text{OK}$$

Check Against Buoyancy

The buoyant upward force is

$$F_u = \pi R_0^2 H \gamma_w$$

For $R_0 = 10 \text{ ft}$,

$$F_u = \frac{(\pi)(10)^2(45)(62.4)}{1000} = 882.2 \text{ kip}$$

The downward force, $F_d = W_c + W_s + Q_s$ and

$$W_c = \pi(R_0^2 - R_i^2)(\gamma_c)(55) = \pi(10^2 - 7.5^2)(150)(55) = 1,133,919 \text{ lb} \approx 1134 \text{ kip}$$

$$W_s = (\pi R_i^2)t\gamma_c = (\pi)(7.5)^2(1)(150) = 26,507 \text{ lb} = 26.5 \text{ kip}$$

Assume that $Q_s \approx 0$. So

$$F_d = 1134 + 26.5 = 1160.5 \text{ kip}$$

Because $F_u < F_d$, it is safe. For design, assume that $t = 2.5 \text{ ft}$.

NPTEL – ADVANCED FOUNDATION ENGINEERING-I

www.kvrssoftwares.blogspot.com/

3. Now the deflections caused by the shear loads $P_f + P_m$ and that caused by the moments $M_f + M_p$ may be written as follows:

$$y_p = y_p + y_{mp} \quad (\text{Eq. 8.33})$$

$$y_m = y_m + y_{pm} \quad (\text{Eq. 8.34})$$

4. Lastly the total deflection y_t is obtained as

$$y_t = \frac{y_p + y_m}{2} = \frac{(y_p + y_{mp}) + (y_m + y_{pm})}{2} \quad (\text{Eq. 8.35})$$

The distribution of moment along a pier may be determined using Fig. 8.14.

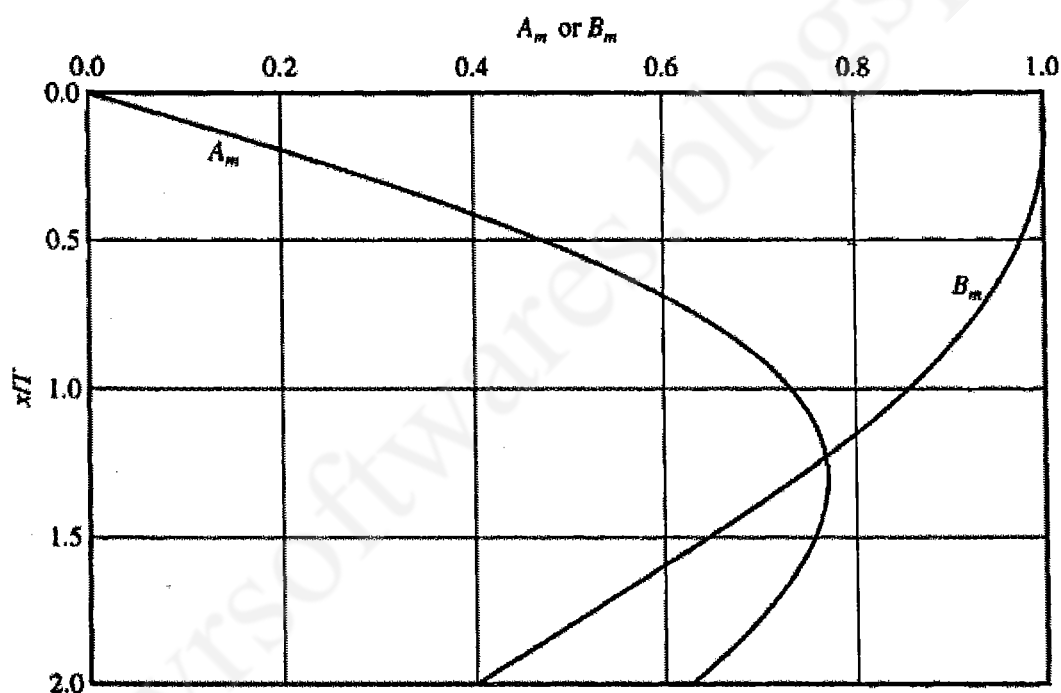

Fig 8.14: Parameters A and B (Matlock and Reese, 1961)

8.14 Types of Caissons

- i. Box caisson: This type of caisson is open at the top and closed at the bottom and is made of reinforced concrete, steel or timber. It is generally recommended when bearing stratum is available at shallow depth.

- ii. Open caisson (wells): Open caisson is a box open both at top and bottom. It is made up of timber, concrete or steel. The open caisson is also called well.
- iii. Pneumatic caissons: It has lower end designed as a working chamber in which compressed air is forced to prevent the entry of water and thus excavation can be done in dry condition.

8.15 Different Shapes of Well

The common types of well shapes are;

1. Single circular
2. Dumb well
3. Twin circular
4. Rectangular
5. Twin octagonal
6. Twin hexagonal
7. Double-D

The choice of a particular shape of well depends upon the size of the pier, the considerations of tilt and the shift during sinking and the vertical and horizontal forces to which well is subjected.

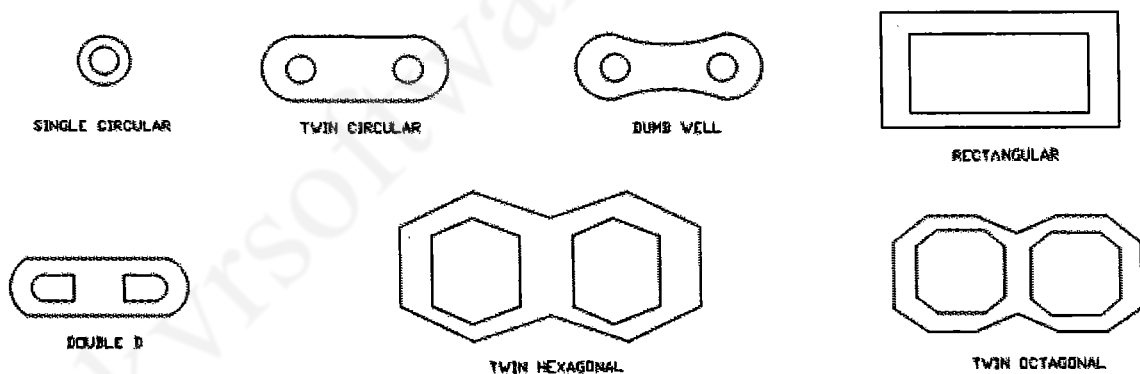

Fig 8.15: Different shapes of well foundation

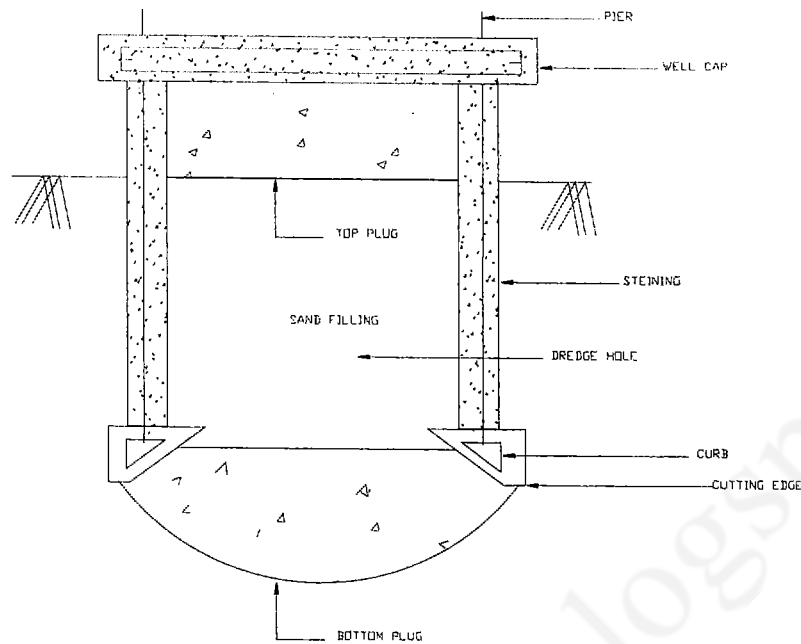

Fig 8.16: Section of well foundation

A circular type well has the minimum perimeter for a given dredge area. Since, perimeter will be equidistant at the points from the centre of dredge-hole; the sinking is more uniform as compared to the other shapes. In circular well a disadvantage is that in the direction parallel to the span of bridge, the diameter of the well is much more than required to accommodate minimum size of pier and hence circular well obstruct water way much in comparison to other shapes.

The following are components of well foundation:

1. Well curb and cutting edges
2. Steining
3. Bottom plug
4. Well cap

8.15.1 Construction of Well Foundation

Well foundations can be constructed on dry bed or after making a sand island. At locations where the depth of water is greater than 5m to 6m and the velocity of water is high, wells can be fabricated at the river bank and then floated to the final position and grounded. Great care is to be exercised while grounding a well to ensure that its position is correct. Once

the well has touched the bed, sand bags are deposited around it to prevent scour. The well may sink into the river bed by 30 to 100cm under its own weight. The well is sunk into the ground to the desired level by extracting soil through the dredge holes. A strong cutting edge is provided to facilitate sinking. The tapered portion of the well above the cutting edge is known as curb. The walls of the well are known as steining. After the well has been sunk to the final position, the bottom plug is formed by concreting. The bottom plug serves as the base of the well. The well is filled with sand partly or completely. At the top of the well, a top plug is formed by concreting & R.C.C well cap is provided at the top to transmit both vertical and lateral loads. The vertical loads comprise the dead and live loads. The live load is brought on to the structure due to the passing of the vehicles over the bridge. The lateral loads are caused due to braking or traction of vehicles, water current, wind, earth quakes etc. The lateral forces might act at different points on a pier, but their effect can be simulated by considering equivalent force acting at bearing level.

8.15.2 Forces Acting on a Well Foundation

1. Braking and tractive effort of the moving vehicles.
2. Force on account of resistance of the moving vehicles.
3. Force on account of water current.
4. Wind forces.
5. Seismic forces.
6. Earth pressure.
7. Centrifugal forces.

8.15.3 Depth of Well Foundation and Bearing Capacity

The depth of well foundation is based on the following 2 criteria.

1. There should be adequate embedded length of well, called the grip length below the lowest scour level.
2. The well should be taken deep enough to rest on strata of adequate bearing capacity in relation to the loads transmitted.

In North Indian rivers usually we meet with alluvial soils.

The normal scour depth can be calculated by Lacey's formula.

$$R_L = 1.35 \left(\frac{q^2}{f} \right)^{\frac{1}{3}} \quad (\text{Eq.8.36})$$

where

q = discharge in cumecs per linear meter of water way

f = Lacey's silt factor = $1.76 \sqrt{m_d}$

m_d = mean weighted diameter in mm.

The maximum depth of scour, at the nose of pier is found to be twice the Lacey's value of normal scour depth.

$R = 2R_L$

where, R is measured below the high flood level (HFL)

scour level = $\text{HFL} - R = \text{HFL} - 2R_L$

The grip length is taken as $1 \frac{1}{3} R$ below the HFL according to IRC code.

It is further recommended that the minimum depth of embedment below the scour level should not be less than 2.0m for piers and abutment with arches and 1.2m for piers and abutments supporting other types of superstructures. Terzaghi and Peck have suggested the ultimate bearing capacity can be determined from the following expression.

$$Q_f = Q_p + 2\pi R f D_f \quad (\text{Eq.8.37})$$

$$Q_p = \pi R^2 (1.2cN_c + \gamma D_f N_q + 0.6\gamma R N_\gamma) \quad (\text{Eq.8.38})$$

where N_c , N_q , N_γ = Terzaghi's bearing capacity factors.

R = radius of well

D_f = depth of well

f_s = average skin friction

8.16 Analysis of Well Foundation

8.16.1 Design of well cap

The well cap supports the substructure of the bridge by spanning the dredge hole of the well and in case of more than one separate well, by spanning the distance between the wells. The top of well caps are usually kept at low water level or low tide level for general appearance and reducing obstruction to the flow. The piers or substructure transmit to the well cap not only

the direct loads but also moments caused by the various horizontal force. The well cap is designed as a slab resting over the top of well.

For circular well, the design of the cap may be done

Consider the forces on the superstructure and substructure, calculate the resultant vertical load (V), moment M_{xx} and moment M_{yy} at the top of well cap.

Compute $M = \sqrt{M_{xx}^2 + M_{yy}^2}$, & $e = M/V$

$$P_{1,2} = \frac{V}{A} \left(1 + \frac{6e}{B} \right)$$

A is area of cross-section of well steining $= \pi(r_1^2 - r_2^2)$

Critical section for finding B.M will be a-a.

Determine pressure intensity at section a-a say P_3 .

Assume that the shaded portion of the cap which is rested on steining is acted upon by a uniform pressure intensity of magnitude $(P_1 + P_2)/2 = P_4$

$$\text{Area of segment of a circle} = \frac{1}{2} [R^2(\theta - \sin \theta)]$$

Distance of c.g. of segment from center of circle $= (4R \sin^3 \theta / 2) / 3(\theta - \sin \theta)$

Determine the areas of segments DEF and ABC with their center of gravities

Moment about section a-a

$$= P_4 A_1 \left(X_1 - \frac{B_p}{2} \right) - P_4 A_2 \left(X_2 - \frac{B_p}{2} \right) - \text{Weight of well cap} / \text{Area of well cap} (X_1 - B_p/2) \quad (\text{Eq.8.39})$$

8.16.2 Design of Well Steining

The well steining is the main body of the well. After determining the maximum moments and loads, the design of well steining through which the forces acting on the bridge are transmitted to the base of well requires to be considered. The moments will go on reducing due to the passive resistance offered by scour level.

The section of well steining just below the well cap has least direct load but is subjected to a considerable moment and therefore, this section is critical for tensile and shear stresses.

At a level below the maximum scour level where the horizontal force gets neutralized by passive pressure of the earth, i.e., where the shear becomes zero, the moments are the maximum and the direct loads are also considerable.

When the well is circular and practically watertight, it is subjected to hoop compression during rising floods.

This hoop compressive stress varies depending on the flood level. Hoop compression in the steining is uniform up to the maximum scour level.

If wells are not circular, the stresses in the steining should be calculated taking the moments caused by the pressure due to differential head in such cases.

8.16.3 Design of Well Curb and Cutting Edge

Well curb now-a-days is usually made of reinforced concrete, with a steel cutting edge. The inner face of the curb is generally sloped two vertical to one horizontal.

The cutting edge of a well is almost made of steel. As it cuts through the bed, it must be extremely strong and rigidly tied to the well curb to withstand distortion, warping, twisting, shearing, crushing and spread out.

The well curb has a shape offering the minimum resistance during sinking, and should be strong enough to be able to transmit superimposed loads from the steining to the bottom plug. The curb should invariably be reinforced concrete of mix not leaner than M30 with minimum reinforcement of 72kg per cum excluding bond roads.

This quantity of steel should be suitably arranged to prevent spreading and splitting of the curb during sinking and in service.

8.16.4 Design of Curb for Sinking

The curb cuts through the soil by the dead weight of the well steining and kentledge, if any, when the inside of the well is dredged. After the well has penetrated the soil to a considerable depth, the forces acting on the curb will be as shown in Fig 8.17.

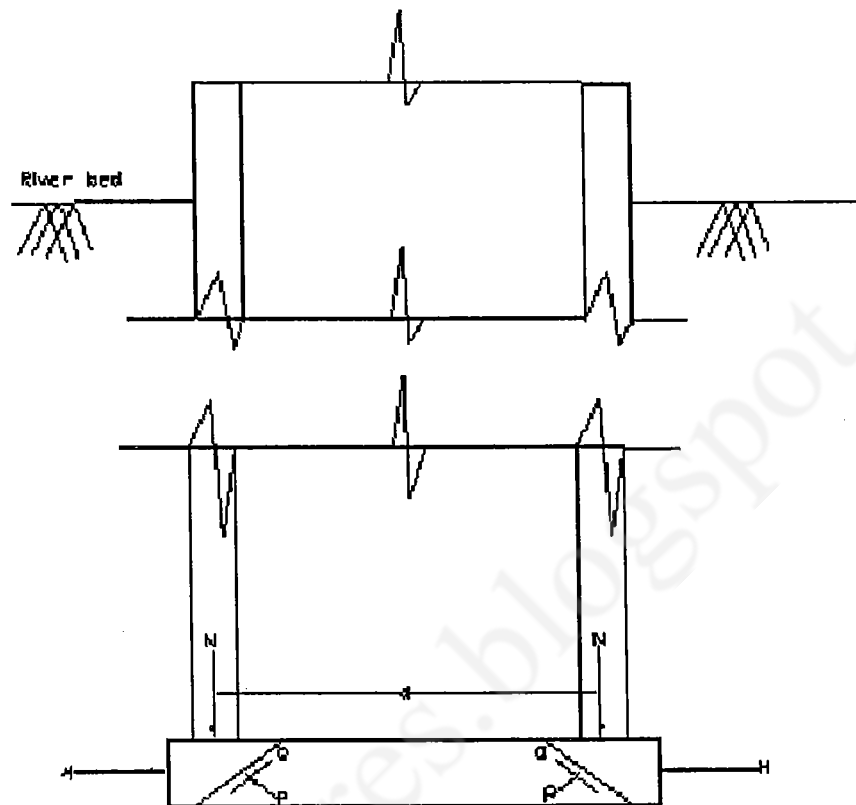

Fig 8.17: Force on well curb during sinking

D = Mean dia of curb in m,

N = weight of steining in kN per m run,

θ = Angle in degrees of beveling face with the horizontal

μ = Coefficient of friction between soil and concrete of curb

P = Force in kN per m run of curb acting normal to the level surface.

Q = Force in kN per m length of curb acting tangentially to the level surface,

H = Horizontal resultant force in kN per m of curb

$$Q = P\mu$$

Resolving vertically

$$\mu P \sin \theta + P \cos \theta = N$$

$$\Rightarrow P = \frac{N}{\mu \sin \theta + \cos \theta}$$

(Eq.8.40)

Resolving horizontally

$$P \sin \theta - \mu P \cos \theta = H$$

$$\Rightarrow H = P(\sin \theta - \mu \cos \theta)$$

$$\text{H per m run} = N \left(\frac{\sin \theta - \mu \cos \theta}{\mu \sin \theta + \cos \theta} \right) \quad (\text{Eq.8.41})$$

$$\text{Total hoop tension} = Hd/2$$

While sinking, active earth pressure of soil or external compression may not develop fully at the curb due to unsettled conditions.

Sometimes, during sinking, sand blow in case of deep dredge may result in sudden descent of well. To account for these eventualities, hoop tension reinforcement is increased by 50% and vertical bond rods are provided.

$$\text{Total hoop tension} = 0.75N \left(\frac{\sin \theta - \mu \cos \theta}{\mu \sin \theta + \cos \theta} \right) d \quad (\text{Eq.8.42})$$

8.16.5 Design of Curb Resting on the Bottom Plug

When the cutting edge is prevented from moving down by the reaction developed at the interface of the curb and the bottom plug, the reaction, neglecting cumulative effect of skin friction, could be resolved into horizontal and vertical components by assuming formation of a two-hinged parabolic arch within the thickness of the bottom plug. The weight of the material filled in the well and the bottom plug will be transmitted to the bed directly.

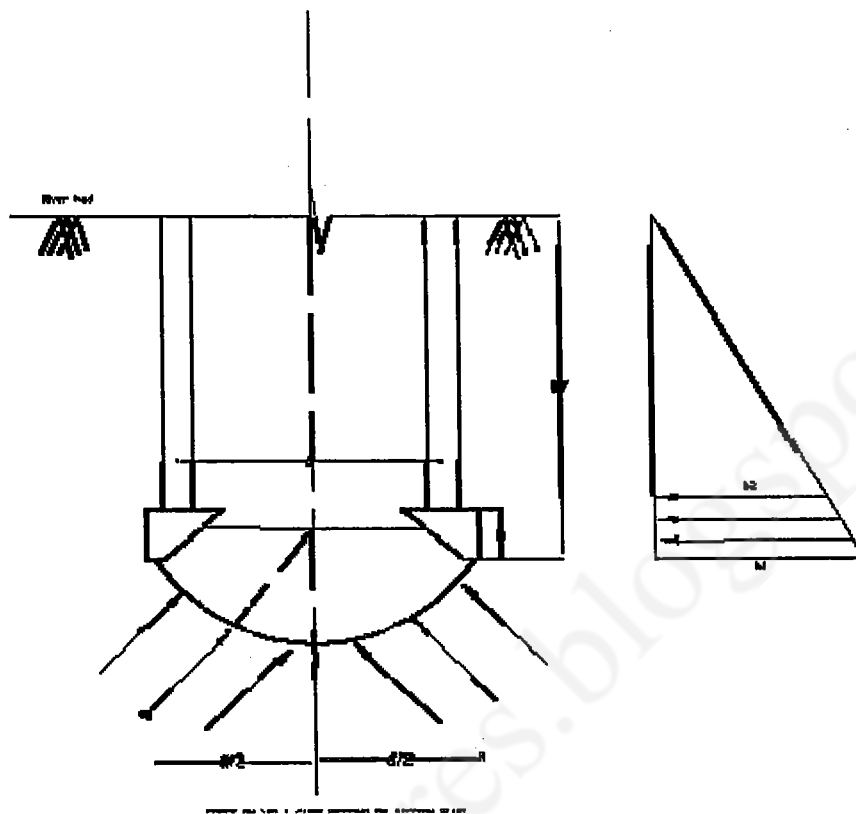

Fig 8.18: Force on well curb resting on bottom plug

For the condition assumed, the hoop tension H is given by the equation.

$$H = \left(\frac{qd^2}{8r} \right) \frac{d}{2} \quad (\text{Eq.8.43})$$

where,

q = Total weight on the base/Area of plug

r = vertical height of imaginary inverted arch

In granular soils, the hoop tension H is relieved by the active pressure around the curb

$$\text{Hoop compression } C = \frac{1}{2} (P_1 + P_2) \frac{bd}{2} \quad (\text{Eq.8.44})$$

P_1 = Active earth pressure at depth D_f

P_2 = Active earth pressure at depth $(D_f - b)$

γ = submerged unit weight of soil

Thus net hoop tension = (H - C)

At the junction provided at the corner to take care of this moment should be taken along the level base and anchored well into the steining.

Design of bottom plug

Based on theory of elasticity, the thickness of the seal t is given by

$$\text{For circular well: } t^2 = \left(\frac{3W}{8f_c\pi} \right) (3 + \nu) \quad (\text{Eq.8.45})$$

If, $W = q\pi r^2$ and $\nu = 0.5$ equation reduce to $t^2 = \frac{1.18r q}{f_c}$

f_c = flexure strength of concrete seal

W = Total bearing pressure on the base of well.

Chapter 1

Soil Exploration

1.1 Introduction

1.1 Introduction

The object of site investigation is to obtain reliable, specific and detailed information about the soil/rock and groundwater conditions at a site for enabling engineers in the safe and economic design and execution of engineering works. To meet this objective investigation should be carried out to the required depth and horizontal extent in the region likely to be affected by the proposed constructions. The investigation should yield precise information about the following:

- i. Order of occurrence and extent of soil/rock strata.
- ii. Nature and engineering properties of the soil/rock strata.
- iii. Location of groundwater table and its fluctuation.

Depth of investigation, in general, is decided based on the intensity of structured loading and the type of foundation contemplated. This depth up to which the increase in stress due to structural loading causes shear failure or excessive settlement of foundation is known as significant depth. This depth of investigation is generally taken as the depth of pressure bulb of intensity $0.1q$ where 'q' is the intensity of loading at the base of foundation. IS 1892 provides the following guidelines for depth of exploration for different types of foundations.

Table 1.1: Depth of exploration (IS: 1892-1979)

Sl no.	Type of foundation	Depth of exploration
1	Isolated spread footings or raft or adjacent footings with clear spacing equal or greater than four times the width	One and half times the width
2	Adjacent footings with clear spacing less than twice the width	One and half times the length

3	Adjacent rows of footings i. With clear spacing between rows less than twice the width ii. With clear spacing between rows greater than twice the width iii. With clear spacing between rows greater than four times the width	Four and half times the width Three times the width One and half times the width
4	Pile and well foundations	One and half times the width of structure from bearing level (toe of pile or bottom of well)
5	Road cuts	Equal to the bottom width of the cut
6	Fill	Two meters below the ground level or equal to the height of the fill, whichever is greater

The number and spacing of borings/test pits depends on the type and size of foundations and extent of variation in soil conditions. IS 1892 makes the following recommendations:

- i. For a compact building site covering an area of about 0.4 hectare, one bore hole or trial pit in each corner and one in the centre should be adequate
- ii. For smaller and less important buildings even one bore hole or trial pit in the centre will suffice.
- iii. For very large areas covering industrial and residential colonies, the geotechnical nature of the terrain will help in deciding the number of bore holes or trial pits.
- iv. Cone penetration tests may be performed at every 50 m by dividing the area in a grid pattern and number of bore holes or trial pits decided by examining the variation in penetration curves. The cone penetration tests may not be possible at sites having gravelly or boulderous strata. In such cases geophysical methods may be suitable.

1.2 Boring of Holes

Making or drilling bore holes into the ground with a view to obtaining soil or rock samples from specified or known depths is called 'boring'. The common methods of advancing bore holes are described below.

1.2.1 Auger Method

Soil auger' is a device that is useful for advancing a bore hole into the ground. Augers may be hand-operated or power-driven; the former are used for relatively small depths (less than 3 to 5 m), while the latter are used for greater depths. The soil auger is advanced by rotating it while pressing it into the soil at the same time. It is used primarily in soils in which the bore hole can be kept dry and unsupported. As soon as the auger gets filled with soil, it is taken out and the soil sample collected.

1.2.1.1 Hand Operated Augers

The term boring refers to making or drilling holes into the ground for the purpose of obtaining samples or conducting insitu tests. Auger boring is the simplest of the methods. Hand operated or power driven augers may be used. Two types of hand operated augers are in use as shown in Fig 1.1. The depths of the holes are normally limited to a maximum of 10 m by this method. These augers are generally suitable for all types of soil above the water table but suitable only in clayey soil below the water table. A string of drill rods is used for advancing the boring. The diameters of the holes normally vary from 10 to 20 cm. Hand operated augers are not suitable in very stiff to hard clay nor in granular soils below the water table. Hand auguring is not practicable in dense sand nor in sand mixed with gravel even if the strata lie above the water table.

1.2.1.2 Power Driven Augers

In many countries the use of power driven continuous flight augers is the most popular method of soil exploration for boring holes. The flights act as a screw conveyor to bring the soil to the surface.

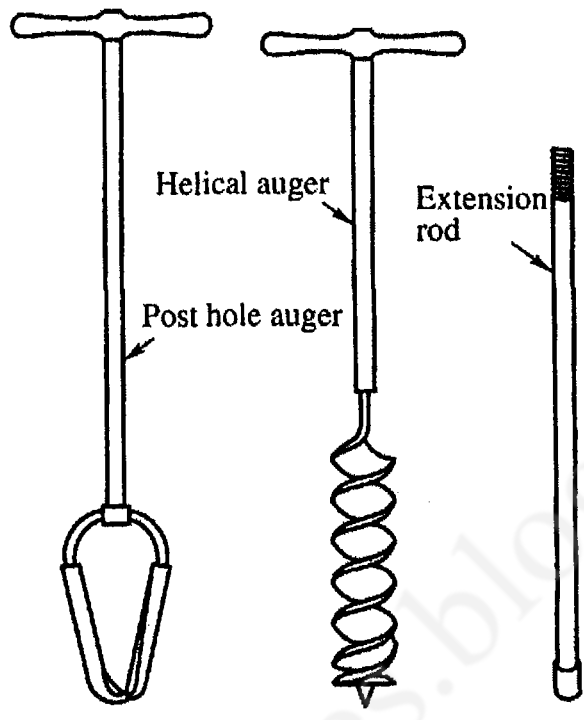

Figure 1.1 Hand augers

www.kvrssoftwares.blogspot.com/

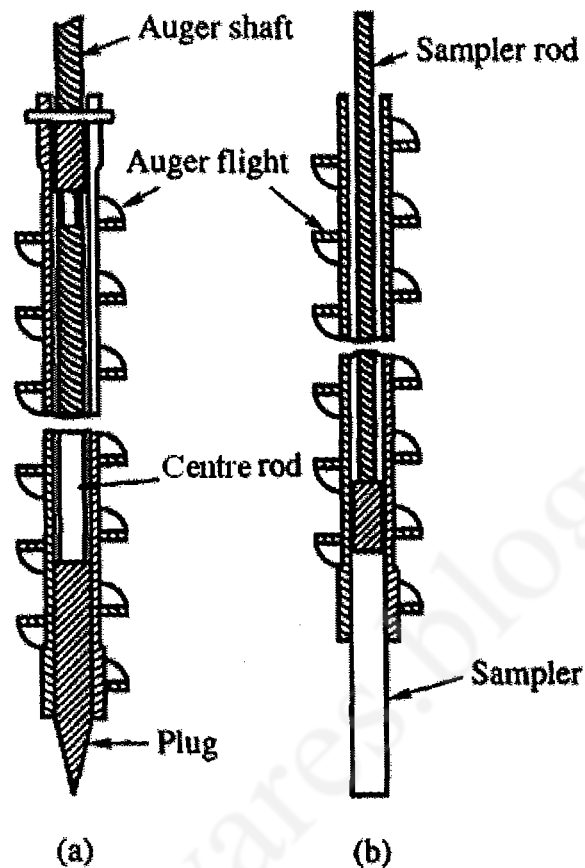

Figure 1.2 Hollow-stem auger

(a) Plugged while advancing the auger, and (b) plug removed and sampler inserted to sample soil below auger

This method may be used in all types of soil including sandy soils below the water table but is not suitable if the soil is mixed with gravel, cobbles etc. The central stem of the auger flight may be hollow or solid. A hollow stem is sometimes preferred since standard penetration tests or sampling may be done through the stem without lifting the auger from its position in the hole. Besides, the flight of augers serves the purpose of casing the hole. The hollow stem can be plugged while advancing the bore and the plug can be removed while taking samples or conducting standard penetration tests as shown in Fig 1.2. The drilling rig

can be mounted on a truck or a tractor. Holes may be drilled by this method rapidly to depths of 60 m or more.

1.2.1.3 Wash Boring

Wash boring is commonly used for boring holes. Soil exploration below the ground water table is usually very difficult to perform by means of pits or auger-holes. Wash boring in such cases is a very convenient method provided the soil is sand, silt, or clay. The method is not suitable if the soil is mixed with gravel or boulders. Fig 1.3 shows the assembly for a wash boring. To start with, the hole is advanced a short depth by auger and then a casing pipe is pushed to prevent the sides from caving in. The hole is then continued by the use of a chopping bit fixed at the end of a string of hollow drill rods. A stream of water under pressure is forced through the rod and the bit into the hole which loosens the soil and as the water flows up around the pipe, the loosened soil in suspension in water is discharged into a tub. The soil in suspension settles down in the tub and the clean water flows into a sump which is reused for circulation. The motive power for a wash boring is either mechanical or man power. The bit which is hollow is screwed to a string of hollow drill rods supported on a tripod by a rope or steel cable passing over a pulley and operated by a winch fixed on one of the legs of the tripod. The purpose of wash boring is to drill holes only and not to make use of the disturbed washed materials for analysis. Whenever an undisturbed sample is required at a particular depth, the boring is stopped, and the chopping bit is replaced by a sampler. The sampler is pushed into the soil at the bottom of the hole and the sample is withdrawn.

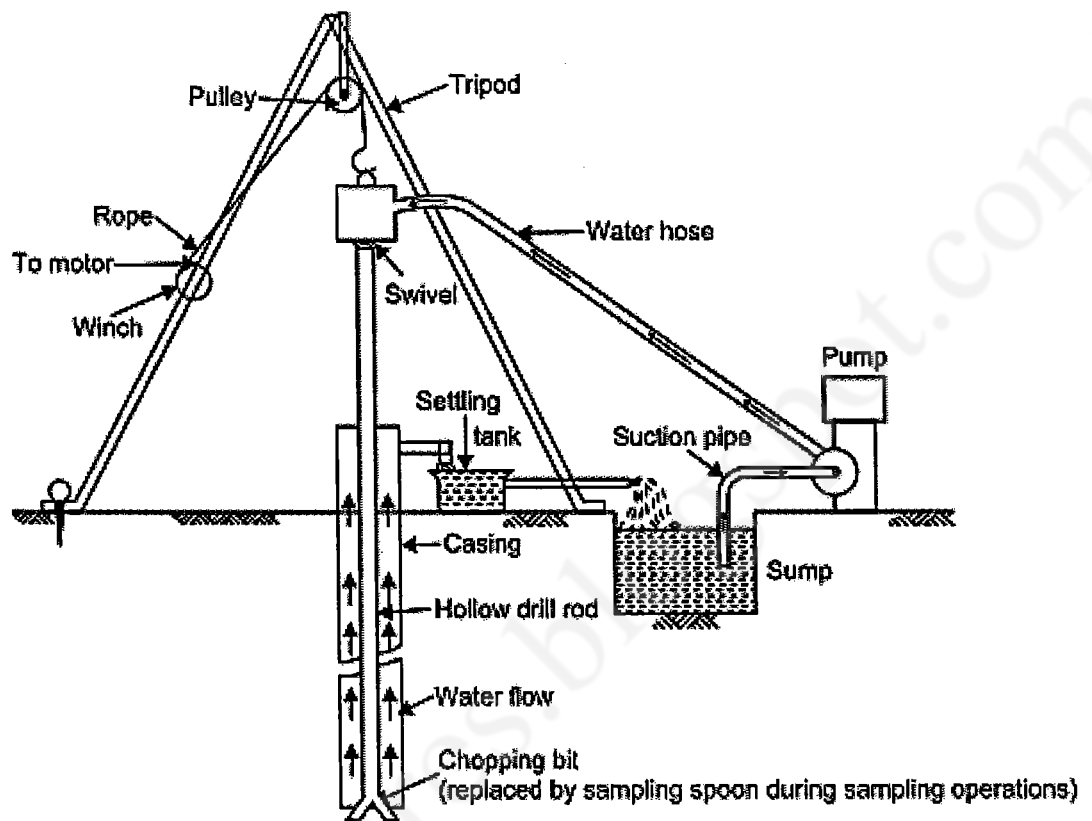

Fig 1.3: Wash boring

1.2.1.4 Rotary Drilling

In the rotary drilling method a cutter bit or a core barrel with a coring bit attached to the end of a string of drill rods is rotated by a power rig. The rotation of the cutting bit shears or chips the material penetrated and the material is washed out of the hole by a stream of water just as in the case of wash boring. Rotary drilling is used primarily for penetrating the overburden between the levels at which samples are required. Coring bits, on the other hand, cut an annular hole around an intact core which enters the barrel and is retrieved. Thus the core barrel is used primarily in rocky strata to get rock samples. As the rods with the attached bit or barrel are rotated, a downward pressure is applied to the drill string to obtain penetration, and drilling fluid under pressure is introduced into the bottom of the hole through the hollow drill rods and the passages in the bit or barrel. This drilling fluid serves the dual function of cooling the bit as it enters the hole and removing the cuttings from the bottom of the hole as it returns to

the surface through the annular space between the drill rods and the walls of the hole. In an uncased hole, the drilling fluid also serves to support the walls of the hole. When boring in soil, the drill bit is removed and replaced by a sampler when sampling is required, but in rocky strata the coring bit is used to obtain continuous rock samples.

1.2.1.5 Coring Bits

The three basic categories of coring bits in use are diamond, carbide insert, and saw tooth. Diamond coring bits may be of the surface set or diamond impregnated type. The most versatile of all coring bits are the diamond coring bits. This is because they produce high quality cores in rock materials ranging from soft to extremely hard. Carbide insert bits use tungsten carbide in lieu of diamonds. Bits of such type are used to core soft to medium hard rock. Even though they are less expensive than diamond bits, the rate of drilling is slower than with diamond bits. The cutting edge comprises a series of teeth in saw tooth bits. The teeth are faced and tipped with a hard metal alloy such as tungsten carbide in order to provide wear resistance and thereby increase the life of the bit. These bits are less expensive but normally used to core overburden soil and very soft rocks only.

1.3 Sampling of soils

Soils met in nature are heterogeneous in character with a mixture of sand, silt and clay in different proportions. In water deposits, there are distinct layers of sand, silt and clay of varying thicknesses and alternating with depth. We can bring all the deposits of soil under two distinct groups for the purpose of study, namely, coarse grained and fine grained soils. Soils with particles of size coarser than 0.075 mm are brought under the category of coarse grained and those finer than 0.075 mm under fine grained soils. Sandy soil falls in the group of coarse grained, and silt and clay soils in the fine grained group. A satisfactory design of a foundation depends upon the accuracy with which the various soil parameters required for the design are obtained. The accuracy of the soil parameters depends upon the accuracy with which representative soil samples are obtained from the field.

1.4 Disturbed Samples

Auger samples may be used to identify soil strata and for field classifications tests, but are not useful for laboratory tests. The cuttings or chopping from wash borings are of little value except for indicating changes in stratification to the boring supervisor. The material brought up with the drilling mud is contaminated and usually unsuitable even for identification. For proper identification and classification of a soil, representative samples are required at frequent intervals along the bore hole. Representative samples can usually be obtained by driving or pushing into the strata in a bore hole an open-ended sampling spoon called a split spoon sampler. It is made up of a driving shoe and a barrel. The barrel is split longitudinally into two halves with a coupling at the upper end for connection to the drill rods. The dimensions of the split spoon are given in Fig 1.4. In a test the sampler is driven into the soil a measured distance. After a sample is taken, the cutting shoe and the coupling are unscrewed and the two halves of the barrel separated to expose the material. Experience indicates that samples recovered by this device are likely to be highly disturbed and as such can only be used as disturbed samples. The samples so obtained are stored in glass or plastic jars or bags, referenced and sent to the laboratory for testing. If spoon samples are to be transported to the laboratory without examination in the field, the barrel is often cored out to hold a cylindrical thin-walled tube known as a liner. After a sample has been obtained, the liner and the sample it contains are removed from the spoon and the ends are sealed with caps or with metal discs and wax. Samples of cohesion less soils below the water table cannot be retained in conventional sampling spoons without the addition of a spring core catcher.

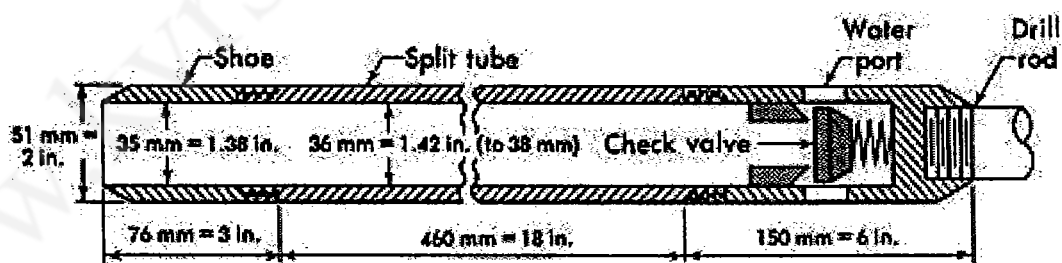

Fig: 1.4: Split spoon sampler

Many types of samplers are in use for extracting the so called undisturbed samples.

Only two types of samplers are described here. They are

1. Open drive sampler
2. Piston sampler.

1.4.1 Open Drive Sampler

The wall thickness of the open drive sampler used for sampling may be thin or thick according to the soil conditions met in the field. The samplers are made of seamless steel pipes. A thin-walled tube sampler also called as Shelby tube sampler (Fig. 1.5), consists of a thin wall metal tube connected to a sampler head. The sampler head contains a ball check valve and ports which allows the escape of air or water from the sample tube as the sample enters it. The thin wall tube, which is normally formed from 1/16 to 1/8 inch metal, is drawn in at the lower end and is reamed so that the inside diameter of the cutting edge is 0.5 to 1.5 percent less than that of the inside diameter of the tube. The exact percentage for this is governed by the size and wall thickness of the tube.

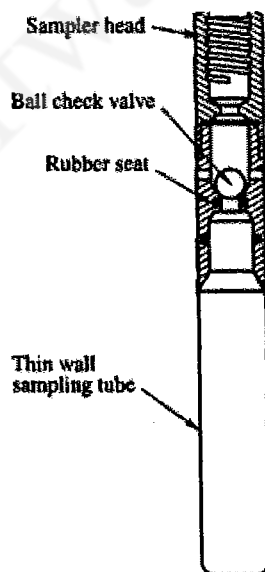

Fig. 1.5: Shelby tube sampler

The wall thickness is governed by the area ratio, A_r , which is defined as

$$A_r = \frac{d_o^2 - d_i^2}{d_i^2}$$

d_o = outside diameter

d_i = inside diameter

A_r is a measure of the volume of the soil displacement to the volume of the collected sample well designed sampling tubes has an area ratio of about 10 percent. However, the area ratio may have to be much more than 10 percent when samples are to be taken in very stiff to hard clay soils mixed with stones to prevent the edges of the sampling tubes from distortion during sampling.

1.5 Standard Penetration Test (SPT)

The SPT is the most commonly used in situ test in a bore hole. The test is made by making use of a split spoon sampler shown in Fig1.4. The method has been standardized as ASTM D-1586 in USA and IS 2131 in India. The method of carrying out this test is as follows:

1. The split spoon sampler is connected to a string of drill rods and is lowered into the bottom of the bore hole which has been drilled and cleaned in advance.
2. The sampler is driven into the soil strata to a maximum depth of 450 mm by making use of a 65 kg weight falling freely from a height of 75 cm on to an anvil fixed on the top of drill rod.

The weight is guided to fall along a guide rod. The weight is raised and allowed to fall by means of a manila rope, one end tied to the weight and the other end passing over a pulley on to a hand operated winch or a motor driven cathead.

3. The number of blows required to penetrate each of the successive 150 mm depths is counted to produce a total penetration of 450 mm.
4. To avoid seating errors, the blows required for the first 150 mm of penetration are not taken into account; blows required to only increase the penetration from 150 mm to 450 mm constitute the N-value.

As per some codes of practice if the N-value exceeds 100, it is termed as refusal, and the test is stopped even if the total penetration falls short of the last 300 mm depth of

penetration. Standardization of refusal at 100 blows allows all the drilling organizations to standardize costs so that higher blows if required may be eliminated to prevent the excessive wear and tear of the equipment. The SPT is conducted normally at 1.5 m interval or at the change of stratum. The intervals may be increased at greater depths if necessary.

Corrections to the Observed SPT Value

Three types of corrections are normally applied to the observed N values. They are:

- 1) Drill rod, sampler and borehole corrections
- 2) Correction due to overburden pressure
- 3) Hammer Efficiency Correction

1.5.1 Drill Rod, Sampler and Borehole Corrections

Correction factors are used for correcting the effects of length of drill rods, use of split spoon sampler with or without liner, and size of bore holes. The various correction factors are (Bowles, 1996)

- a) Drill rod length correction factor C_d

Length	Correction factor C_d
> 10 m	1.0
4-10 m	0.85 – 0.95
< 4.0 m	0.75

- b) Sampler correction factor C_s

Without liner $C_s = 1.00$

With liner,

Dense sand, clay, $C_s = 0.80$

Loose sand, $C_s = 0.90$

- c) Bore hole diameter correction factor C_b

Bore hole diameter	Correction factor C_b
--------------------	-------------------------

60 – 120 mm	1.0
150 mm	1.05
200 mm	1.15

1.5.2 Correction Factor for Overburden Pressure in Granular Soils, C_N

The C_N as per Liao and Whitman (1986) is

$$C_N = \left[\frac{95.76}{\rho'_0} \right]^{\frac{1}{2}}$$

.....Eq 1.1

where, ρ'_0 = effective overburden pressure in kN/m²

There are a number of empirical relations proposed for C_N . However, the most commonly used relationship is the one given by Eq 1.1

N_{cor} may be expressed as

$$N_{cor} = C_N N E_h C_d C_s C_b$$

.....Eq 1.2

N_{cor} is related to the standard energy ratio used by the designer. N_{cor} may be expressed as

N_{70} or N_{60} according to the designer's choice.

In Eq 1.2 $C_N N$ is the corrected value for overburden pressure only. The value of C_N as per Eq 1.1 is applicable for granular soils only, whereas $C_N = 1$ for cohesive soils for all depths.

1.5.3 Hammer Efficiency Correction

Different types of hammers are in use for driving the drill rods. Two types are normally used worldwide. They are (Bowles, 1996)

- 1) Donut with two turns of manila rope on the cathead with a hammer efficiency $E_h = 0.45$.
- 2) Safety with two turns of manila rope on the cathead with a hammer efficiency as follows:

Rope-pulley or cathead, $E_h = 0.7$ to 0.8 ;

Trip or automatic hammer, $E_h = 0.8$ to 1.0 .

Table 1.2: N_{cor} and ϕ Related to Relative density

N_{cor}	Compactness	Relative density, D_r (%)	ϕ (°)
0 - 4	Very loose	0 - 15	< 28
4 - 10	Loose	15 - 35	28 - 30
10 - 30	Medium	35 - 65	30 - 36
30 - 50	Dense	65 - 85	36 - 41
>50	Very dense	> 85	> 41

Table 1.3: Relation between N_{cor} and q_u

Consistency	N_{cor}	q_u kPa
Very soft	0 - 2	< 25
Soft	2 - 4	25 - 50
Medium	4 - 8	50 - 100
Stiff	8 - 15	100 - 200
Very Stiff	15 - 30	200 - 400
Hard	> 30	> 400

where, q_u is the unconfined compressive strength.

1.6 Cone Penetration Test (CPT)

The static cone penetration test normally called the Dutch cone penetration test (CPT) has gained acceptance rapidly in many countries. The method was introduced nearly 50 years ago. One of the greatest values of the CPT consists of its function as a scale model pile test. Empirical correlations established over many years permit the calculation of pile bearing capacity directly from the CPT results without the use of conventional soil parameters. The CPT has proved valuable for soil profiling, as the soil type can be identified from the combined measurement of end resistance of cone and side friction on a jacket. The test lends itself to the derivation of normal soil properties such as density, friction angle and cohesion. Various theories have been developed for foundation design.

The popularity of the CPT can be attributed to the following three important factors:

- 1) General introduction of the electric penetrometer providing more precise measurements, and improvements in the equipment allowing deeper penetration.
- 2) The need for the penetrometer testing in-situ technique in offshore foundation investigations in view of the difficulties in achieving the adequate sample quality in marine environment.
- 3) The addition of other simultaneous measurements to the standard cone penetrometers such as soil temperature and pore pressure.

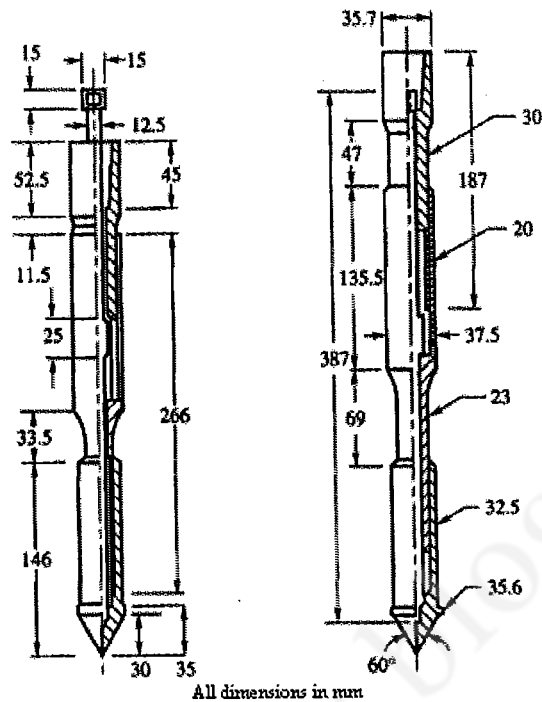

Fig 1.6: Standard cone Penetrometer

1.7 Operation of Penetrometer

The sequence of operation of the penetrometer shown in Fig 1.7. is explained as follows:

Position 1: The cone and friction jacket assembly in a collapsed position.

Position 2: The cone is pushed down by the inner sounding rods to a depth until a collar engages the cone. The pressure gauge records the total force Q_c to the cone. Normally $a = 40$ mm.

Position 3: The sounding rod is pushed further to a depth b . This pushes the friction jacket and the cone assembly together; the force is Q_t . Normally $b = 40$ mm.

Position 4: The outside mantle tube is pushed down a distance $a + b$ which brings the cone assembly and the friction jacket to position 1. The total movement $= a + b = 80$ mm.

The process of operation illustrated above is continued until the proposed depth is reached.

The cone is pushed at a standard rate of 20 mm per second. The mechanical penetrometer has its advantage as it is simple to operate and the cost of maintenance is low. The quality of the work depends on the skill of the operator. The depth of CPT is measured by recording the length of the sounding rods that have been pushed into the ground.

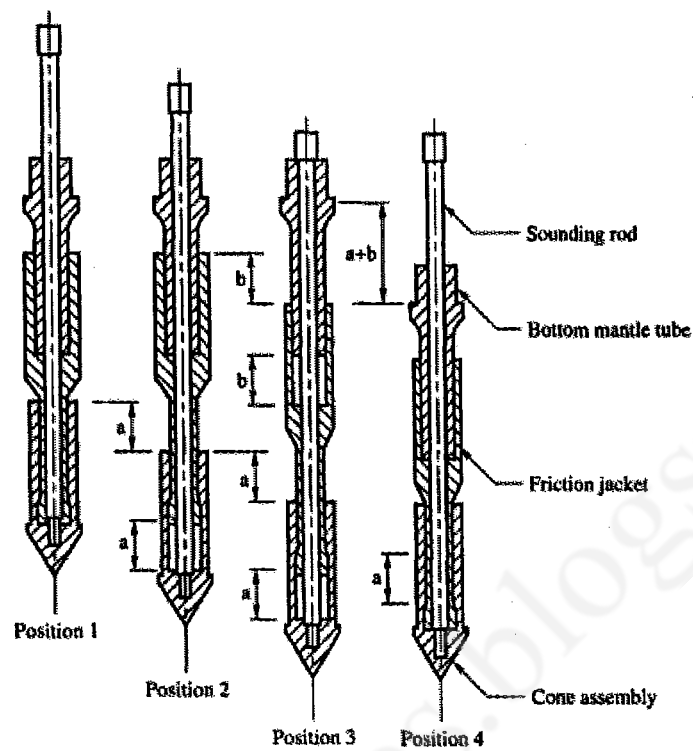

Fig 1.7: Operation of cone Penetrometer

Table 1.4: Soil classification based on friction ratio R_f (Sanglerat, 1972)

R_f (%)	Type of soil
0 – 0.5	Loose gravel fill
0.5 – 2	Sands or gravels
2 - 5	Clay sand mixtures and silts
> 5	Clay, peats etc

1.8 Correlation between SPT and CPT

Meyerhof (1965) presented correlation between SPT and CPT. For fine or silty medium loose to medium dense sands, he presents the correlation as

$$q_c = 0.4 N \text{ MN/m}^2$$

His findings are given in Table 1.5

Table 1.5: Approximate relationship between relative density of fine sand, the SPT, the static cone resistance and the angle of internal friction (Meyerhof, 1965)

State of sand	D_r	N_{cor}	q_c MPa	ϕ (°)
Very loose	< 0.2	< 4	< 2.0	< 30
Loose	0.2 – 0.4	4 - 10	2 – 5	30 - 35
Medium dense	0.4 – 0.6	10 – 30	5 – 10	35- 40
Dense	0.6 – 0.8	30 – 50	10 – 20	40 - 45
Very dense	0.8 – 1.0	>50	> 20	>45

1.9 Geophysical Exploration

The stratification of soils and rocks can be determined by geophysical methods of exploration which measure changes in certain physical characteristics of these materials, for example magnetism, density, electrical resistivity, elasticity or a combination of these properties. However, the utility of these methods in the field of foundation engineering is very limited since the methods do not quantify the characteristics of the various substrata. Vital information on ground water conditions is usually lacking. Geophysical methods at best provide some missing information between widely spaced bore holes but they cannot replace bore holes. Two methods of exploration which are sometimes useful are discussed briefly in this section. They are

1. Seismic Refraction Method,
2. Electrical Resistivity Method.

1.9.1 Seismic Refraction Method

The seismic refraction method is based on the fact that seismic waves have different velocities in different types of soils (or rocks). The waves refract when they cross boundaries between different types of soils. If artificial impulses are produced either by detonation of explosives or mechanical blows with a heavy hammer at the ground surface or at shallow depth within a hole, these shocks generate three types of waves. In general, only compression waves i.e., longitudinal waves are observed. These waves are classified as either direct, reflected or refracted waves. Direct waves travel in approximately straight lines from the source of the impulse to the surface. Reflected or refracted waves undergo a change in direction when they encounter a boundary, a separating media of different seismic velocities. The seismic refraction method is more suited to shallow exploration for civil engineering purposes. The method starts by inducing impact or shock waves into the soil at a particular location. The shock waves are picked up by geophones. In Fig. 1.8(a), point A is the source of seismic impulse. The points D_1, D_2, \dots, D_8 represent the locations of the geophones or detectors which are installed in a straight line. The spacings of the geophones depend on the amount of detail required and the depth of the strata being investigated. In general, the spacing must be such that the distance from D_1 to D_8 is around three to four times the depth to be investigated. The geophones are connected by cable to a central recording device. A series of detonations or impacts are produced and the arrival time of the first wave at each geophone position is recorded in turn. When the distance between source and geophone is short, the arrival time will be that of a direct wave. When the distance exceeds a certain value (depending on the thickness of the stratum), the refracted wave will be the first to be detected by the geophone. This is because the refracted wave, although longer than that of the direct wave, passes through a stratum of higher seismic velocity. A typical plot of test results for a three layer system is given in Fig. 1.8(a) with the arrival time plotted against the distance source and geophone. As in the figure, if the source-geophone spacing is more than the distance d_1 which is the distance from the source to point B, the direct wave reaches the geophone in advance of the refracted wave and the time-distance relationship is represented by a straight line AB through the origin represented by A. If on the other hand, the source geophone distance is greater than d_2 , the refracted waves arrive in advance of the direct waves and the time-distance relationship is represented by another straight line BC which will have a slope different from that of AB. The slopes of

the lines AB and BC are represented by $1/V_1$ and $1/V_2$ respectively, where V_1 and V_2 are the velocities of the upper and lower strata respectively.

The general types of soils or rocks can be determined from knowledge of these velocities. The depth H_1 of the top strata (provided the thickness of the stratum is constant) can be estimated from the formula

$$H_1 = \frac{d_1}{2} \sqrt{\frac{V_1 - V_2}{V_2 + V_1}}$$

.....Eq 1.3a

The thickness of the second layer (H_2) is obtained from

$$H_2 = 0.85H_1 + \frac{d_2}{2} \sqrt{\frac{V_3 - V_2}{V_3 + V_2}}$$

.....Eq 1.3b

The procedure is continued if there are more than three layers.

If the thickness of any stratum is not constant, average thickness is taken.

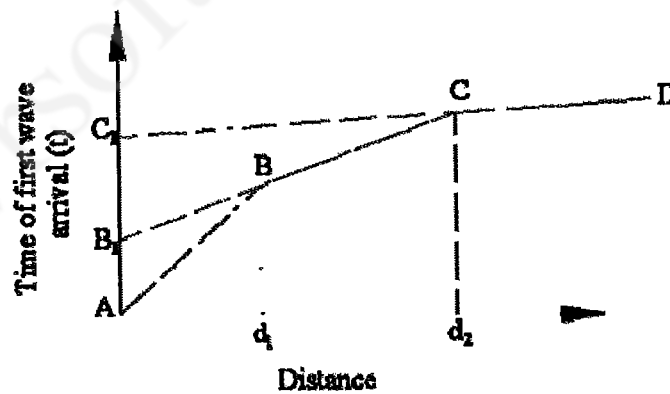

$$\text{Slope of AB} = \frac{1}{V_1}$$

$$\text{Slope of BC} = \frac{1}{V_2}$$

$$\text{Slope of CD} = \frac{1}{V_3}$$

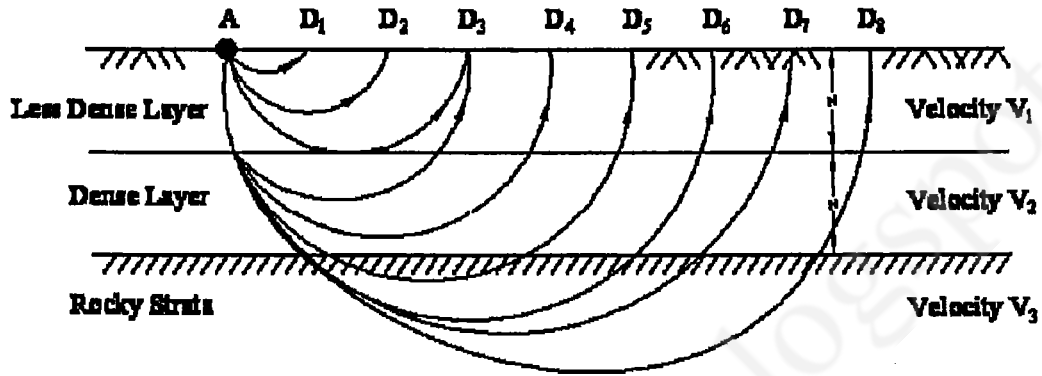

(a) Schematic Representation of seismic refraction method

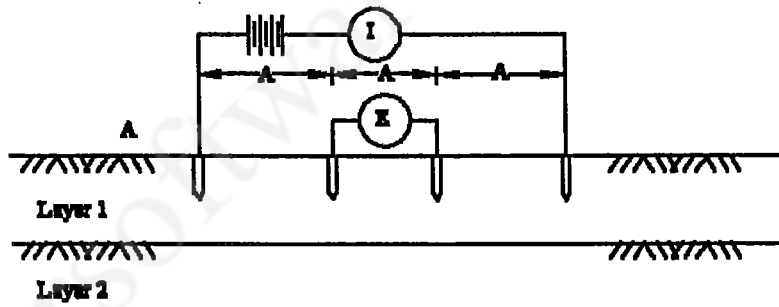

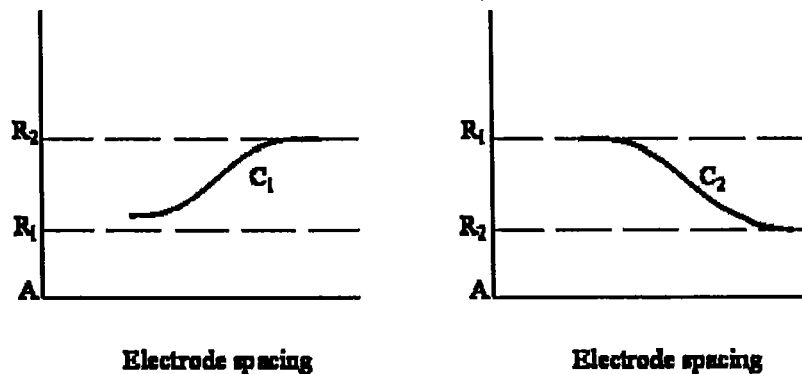

(b) Schematic representation of electrical resistivity method

Fig 1.8: Geophysical methods

1.9.2 Electrical Resistivity Method

This method depends on differences in the electrical resistance of different soil (and rock) types. The flow of current through a soil is mainly due to electrolytic action and therefore depends on the concentration of dissolved salts in the pores. The mineral particles of soil are poor conductors of current. The resistivity of soil, therefore, decreases as both water content and concentration of salts increase. Dense clean sand above the water table, for example, would exhibit a high resistivity due to its low degree of saturation and virtual absence of dissolved salts. Saturated clay of high void ratio, on the other hand, would exhibit a low resistivity due to the relative abundance of pore water and the free ions in that water. There are several methods by which the field resistivity measurements are made. The most popular of the methods is the Wenner Method.

Wenner Method

The Wenner arrangement consists of four equally spaced electrodes driven approximately 20 cm into the ground as shown in Fig. 1.8(b). In this method a dc current of known magnitude is passed between the two outer (current) electrodes, thereby producing an electric field within the soil, whose pattern can be determined by the resistivities of the soils present within the field and the boundary conditions. By means of the inner electrodes the potential

drop 'E' for the surface current flow lines is measured. The apparent resistivity 'R', is given by the equation

$$R = \frac{2\pi AE}{I}$$

It is customary to express A in centimeters, E in volts, I in amperes, and R in ohm-cm. The apparent resistivity represents a weighted average of true resistivity to a depth A in a large volume of soil, the soil close to the surface being more heavily weighted than the soil at greater depths. The presence of a stratum of low resistivity forces the current to flow closer to the surface resulting in a higher voltage drop and hence a higher value of apparent resistivity. The opposite is true if a stratum of low resistivity lies below a stratum of high resistivity.

The method known as electrical sounding is used when the variation of resistivity with depth is required. This enables rough estimates to be made of the types and depths of strata. A series of readings are taken, the (equal) spacing of the electrodes being increased for each successive reading. However, the center of the four electrodes remains at a fixed point. As the spacing is increased, the apparent resistivity is influenced by a greater depth of soil. If the resistivity increases with the increasing electrode spacing, it can be concluded that an underlying stratum of higher resistivity is beginning to influence the readings. If increased separation produces decreasing resistivity, on the other hand, a lower resistivity is beginning to influence the readings.

Apparent resistivity is plotted against spacing, preferably, on log paper. Characteristic curves for a two layer structure are shown in Fig. 1.8(b). For curve C₁ the resistivity of layer 1 is lower than that of 2; for curve C₂, layer 1 has a higher resistivity than that of layer 2. The curves become asymptotic to lines representing the true resistance R₁ and R₂ of the respective layers. Approximate layer thickness can be obtained by comparing the observed curves of resistivity versus electrode spacing with a set of standard curves. The procedure known as electrical profiling is used in the investigation of lateral variation of soil types. A series of readings is taken, the four electrodes being moved laterally as a unit for each successive reading; the electrode spacing remains constant for each reading of the series. Apparent resistivity is plotted against the center position of the four electrodes, to natural scale; such a plot can be used to locate the position of a soil of high or low resistivity. Contours of resistivity can be plotted over

a given area. The electrical method of exploration has been found to be not as reliable as the seismic method as the apparent resistivity of a particular soil or rock can vary over a wide range of values. Representative values of resistivity are given in Table 1.6.

Table 1.6: Representative values of resistivity. The values are expressed in units of 10^3 ohm-cm (after Peck et al, 1974)

Material	Resistivity ohm-cm
Clay and saturated silt	0 - 10
Sandy clay and wet silty sand	10 - 25
Clayey sand and saturated sand	25 - 50
Sand	50 - 150
Gravel	150 - 500
Weathered rock	100 - 200
Sound rock	150 - 4000

1.10 Soil Report

A report is the final document of the whole exercise of soil exploration. A report should be comprehensive, clear and to the point. Many can write reports, but only a very few can produce a good report. A report writer should be knowledgeable, practical, and pragmatic. No theory, books or codes of practice provide all the materials required to produce a good report. It is the experience of a number of years of dedicated service in the field which helps a geotechnical consultant make report writing an art. A good report should normally comprise the following:

1. A general description of the nature of the project and its importance.
2. A general description of the topographical features and hydraulic conditions of the site.
3. A brief description of the various field and laboratory tests carried out.

4. Analysis and discussion of the test results
5. Recommendations
6. Calculations for determining safe bearing pressures, pile loads, etc.
7. Tables containing bore logs, and other field and laboratory test results
8. Drawings which include an index plan, a site-plan, test results plotted in the form of graphs and charts, soil profiles, etc.

1.11 Borehole Log

A borehole log is a record of information obtained from in situ tests and summary of laboratory tests on samples for a particular borehole. It includes description or classification of various soil / rock types at different depths with summary of essential properties including presence or otherwise of ground water table. A typical Borehole log is illustrated in Fig 1.9

Job No.	Date: 06-04-1984
Project: Farakka STPP	BH No.: 1
	GL: 64.3 m
Location: WB	WTL: 63.0 m
Boring method: Shell & Auger	Supervisor: X
Dia of BH: 15 cm	

Soil Type	Level m	Depth m	SPT				Sample type	Remarks
			15 cm	15 cm	15 cm	N		
Yellowish stiff clay	62.3	1.0	4	6	8	14	D U	
Greyish sandy silt med. dense	59.8	3.3	7	10	16	26	D W	
Greyish silty sand dense	56.3	5.0	14	16	21	37	D	
	56.3	7.5	15	18	23	41	D U	
Blackish very stiff clay	53.3	9.0	9	10	14	24	D	
	53.3	11.0						

D = disturbed sample

U = undisturbed sample

W = water sample

N = SPT value

Fig 1.9: Typical borehole log